



JOHNSON PUMP
AN SPX BRAND

Instruction Manual

CombiSump

Vertical long shaft sump pump
according to ISO 2858, EN 733, API 610



Original instructions

Read and understand this manual prior to
operating or servicing this product.

CS/EN (0912) 5.2

SPX[®]

EC Declaration of conformity (valid until 30-12-2009)

(Directive 98/37/EC, appendix II-A)

Manufacturer

SPX Process Equipment NL B.V.
Dr. A.F. Philipsweg 51
P.O. Box 9
9400 AA Assen
The Netherlands

hereby declares that the pump, in case it is delivered as an assembly with drive (last position of serial number = A), is in conformity with the provisions of Directive 98/37/EC (as altered most recently) and the following directives and standards:

- EC directive 2006/95/EG, "Electric equipment for use within certain voltage limits"
- standards EN-ISO 12100 part 1 & 2, EN 809

The pump to which this declaration refers may only be put into operation after it has been installed in the way prescribed by the manufacturer, and, as the case may be, after the complete system of which this pump forms part, has been made to fulfil the requirements of Directive 98/37/EC (as altered most recently).

Manufacturer's declaration (valid until 30-12-2009)

(Directive 98/37/EC, appendix II-B)

Manufacturer

SPX Process Equipment NL B.V.
Dr. A.F. Philipsweg 51
P.O. Box 9
9400 AA Assen
The Netherlands

hereby declares that the pump, in case it is delivered without drive (last position of serial number = B), is in conformity with the following standards:

- EN-ISO 12100 parts 1 & 2, EN 809

and that this pump is meant to be incorporated in or combined with another machine (electric motor, combustion engine) and may only be put into use after the complete machine of which the pump under consideration forms part has been made and declared to comply with that directive.

Assen, November 1st 2009

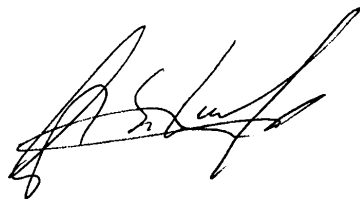

G.A. Schaafsma,
General manager

EC Declaration of conformity (valid from 30-12-2009)

(Directive 2006/42/EC, appendix II-A)

Manufacturer

SPX Process Equipment NL B.V.
Dr. A.F. Philipsweg 51
9403 AD Assen
The Netherlands

hereby declares that all pumps member of productfamilies CombiBloc, CombiBlocHorti, CombiChem, CombiDirt, CombiFlex(U)(B), CombiPrime H, CombiLine, CombiLineBloc, CombiMag, CombiMagBloc, CombiNorm, CombiPro(M)(V), CombiPrime V, CombiSump, CombiWell, FRE, FRES, FREF, FREM, KGE(L), KGEF, HCR, MCH(W)(S), MCHZ(W)(S), MCV)(S), PHA, MDR whether delivered without drive (last position of serial number = B), or delivered as an assembly with drive (last position of serial number = A), are in conformity with the provisions of Directive 2006/42/EC (as altered most recently) and where applicable the following directives and standards:

- EC directive 2006/95/EG, "Electric equipment for use within certain voltage limits"
- standards EN-ISO 12100 part 1 & 2, EN 809

The pumps to which this declaration refers may only be put into operation after they have been installed in the way prescribed by the manufacturer, and, as the case may be, after the complete system of which these pumps form part, has been made to fulfil the requirements of Directive 2006/42/EC (as altered most recently).

Declaration of incorporation (valid from 30-12-2009)

(Directive 2006/42/EC, appendix II-B)

Manufacturer

SPX Process Equipment NL B.V.
Dr. A.F. Philipsweg 51
9403 AD Assen
The Netherlands

hereby declares that the partly completed pump (Back-Pull-Out unit), member of productfamilies CombiBloc, CombiBlocHorti, CombiChem, CombiDirt, CombiFlex(U)(B), CombiPrime H, CombiLine, CombiLineBloc, CombiMag, CombiMagBloc, CombiNorm, CombiPro(M)(V), CombiPrime V, FRE, FRES, FREF, FREM, KGE(L), KGEF, HCR, PHA, MDR is in conformity with the following standards:

- EN-ISO 12100 parts 1 & 2, EN 809

and that this partly completed pump is meant to be incorporated into the specified pump unit and may only be put into use after the complete machine of which the pump under consideration forms part has been made and declared to comply with that directive.

Assen, November 1st 2009

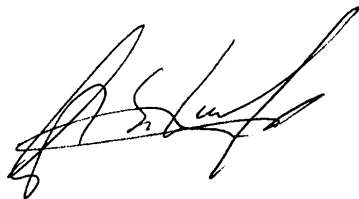

G.A. Schaafsma,
General Manager

Instruction manual

CombiSump

All technical and technological information in this manual as well as possible drawings made available by us remain our property and shall not be used (otherwise than for the operation of this pump), copied, duplicated, made available to or brought to the notice of third parties without our prior written consent.

SPX Process Equipment NL B.V. (hereafter called Johnson Pump) is part of SPX Process Equipment AB. The core activities of SPX Process Equipment AB are the development, production, sale and maintenance of pumps and pump units.

SPX Process Equipment NL B.V.
P.O. Box 9
9400 AA Assen
The Netherlands
Tel. +31 (0)592 376767
Fax. +31 (0)592 376760
www.johnson-pump.com or www.spxpe.com

© 2008 SPX Process Equipment NL B.V.

Table of Contents

1	Introduction	9
1.1	Preface	9
1.2	Safety	9
1.3	Guarantee	10
1.4	Inspection of delivered items	10
1.5	Instructions for transport and storage	10
1.5.1	Dimensions and weight	10
1.5.2	Use of pallets	10
1.5.3	Hoisting	11
1.5.4	Storage	12
1.6	Ordering parts	12
2	General	13
2.1	Pump description	13
2.2	Type code	13
2.3	Serial number	14
2.4	Applications	14
2.5	Construction	14
2.5.1	Dry part	14
2.5.2	Submersible part	14
2.5.3	Pump casing/impeller	14
2.5.4	Shaft sealing	15
2.5.5	Bearing construction	15
2.6	Application area	15
2.7	Re-use	15
2.8	Scrapping	15
3	Installation	17
3.1	Safety	17
3.2	Environment	17
3.3	Mounting	18
3.3.1	Assembling a pump unit	18
3.3.2	Placing a pump unit	18
3.4	Connecting the electric motor	18
3.5	Checking the sense of rotation	18
3.6	Fitting the coupling	18
3.7	Alignment of the coupling	19
3.7.1	Tolerances for aligning the coupling	20
3.8	Piping	20
4	Commissioning	21

4.1	Inspection of the pump	21
4.2	Liquid level	21
4.3	Preparing the unit for commissioning	21
4.4	Starting the pump	21
4.5	Adjustment of shaft sealing	22
4.5.1	Stuffing box packing	22
4.5.2	Mechanical seal	22
4.6	Noise	22
5	Maintenance	23
5.1	Daily maintenance	23
5.2	Shaft sealing	23
5.2.1	Stuffing box packing	23
5.2.2	Mechanical seal	23
5.2.3	Flushing liquid	23
5.3	Lubrication of the bearings	24
5.4	Environmental influences	24
5.5	Noise	24
5.6	Faults	24
6	Problem solving	25
7	Disassembly and assembly	27
7.1	Precautionary measures	27
7.2	Special tools	27
7.3	Designation of parts	27
7.3.1	Position numbers	27
7.3.2	Constructive variants	27
7.4	Dismantling	28
7.4.1	Disconnection of the pump unit	28
7.4.2	Liquid draining	28
7.5	Disassembly	29
7.5.1	Disassembly of the delivery pipe	29
7.5.2	Disassembly of the electric motor	29
7.5.3	Disassembly ball bearing	30
7.5.4	Disassembly shaft sealing group S3	30
7.5.5	Replacement gland packing shaft sealing group S3	31
7.5.6	Disassembly mechanical seal M2	31
7.5.7	Disassembly pump casing/impeller	32
7.5.8	Disassembly pump shaft	33
7.5.9	Disassembly standpipes and intermediate bearings	33
7.5.10	Disassembling the wear ring	34
7.5.11	Assembling the wear ring	34
7.6	Assembly of the submersible part without intermediate bearings	35
7.6.1	Conventions	35
7.6.2	Preparation of the submersible part without intermediate bearings	35
7.6.3	Assembly of shaft and standpipe without intermediate bearings	35
7.7	Assembly of submersible part with intermediate bearings	35
7.7.1	Preparation submersible part with intermediate bearings	35
7.7.2	Assembly shaft with intermediate bearings	35
7.7.3	Assembly standpipe with intermediate bearings	36
7.8	Assembly shaft sealing group S3	36
7.9	Assembly shaft sealing group M2	37
7.10	Assembly of the ball bearing	38
7.11	Assembly of the lantern piece with the electric motor	38
7.12	Mounting the delivery pipe	39

8	Dimensions	41
9	Parts	43
9.1	Ordering parts	43
9.1.1	Order form	43
9.1.2	Recommended spare parts	43
9.2	Pump with shaft sealing group S0	44
9.2.1	Sectional drawing	44
9.2.2	Parts list	45
9.3	Pump with shaft sealing group S3	48
9.3.1	Sectional drawing	48
9.3.2	Parts list	49
9.4	Pump with shaft sealing group M2	52
9.4.1	Sectional drawing	52
9.4.2	Parts list	53
9.5	Pump with shaft sealing group S0, bearing bracket group 4	56
9.5.1	Sectional drawing	56
9.5.2	Parts list	57
10	Technical data	61
10.1	Grease	61
10.2	Recommended greases for assembly	61
10.3	Recommended locking liquids	61
10.4	Tightening moments	62
10.4.1	Tightening moments for bolts and nuts	62
10.4.2	Tightening moments for cap nut	62
10.5	Operational range	63
10.6	Maximum allowable working pressures	64
10.7	Liquid level	65
10.8	Noise data	66
10.8.1	Pump noise as a function of pump power	66
10.8.2	Noise level of entire pump unit	67
	Index	69
	Order form for spare parts	71

1 Introduction

1.1 Preface

This manual is intended for technicians and maintenance staff and for those who are in charge of ordering spare parts.

This manual contains important and useful information for the proper operation and maintenance of this pump. It also contains important instructions to prevent potential accidents and damage, and to ensure safe and fault-free operation of this pump.



Read this manual carefully before commissioning the pump, familiarize yourself with the operation of the pump and strictly obey the instructions!

The data published here comply with the most recent information at the time of going to press. However they may be subject to later modifications.

Johnson Pump reserves the right to change the construction and design of the products at any time without being obliged to change earlier deliveries accordingly.

1.2 Safety

This manual contains instructions for working safely with the pump. Operators and maintenance staff must be familiar with these instructions.

Below is a list of the symbols used for those instructions and their meaning:



Personal danger for the user. Strict and prompt observance of the corresponding instruction is imperative!



Risk of damage or poor operation of the pump. Follow the corresponding instruction to avoid this risk.



Useful instruction or tip for the user.

Items which require extra attention are shown in **bold print**.

This manual has been compiled by Johnson Pump with the utmost care. Nevertheless Johnson Pump cannot guarantee the completeness of this information and therefore assumes no liability for possible deficiencies in this manual. The buyer/user shall at all times be responsible for testing the information and for taking any additional and/or deviating safety measures. Johnson Pump reserves the right to change safety instructions.

1.3 Guarantee

Johnson Pump shall not be bound to any guarantee other than the guarantee accepted by Johnson Pump. In particular, Johnson Pump will not assume any liability for explicit and/or implicit guarantees such as but not limited to the marketability and/or suitability of the products supplied.

The guarantee will be cancelled immediately and legally if:

- Service and/or maintenance is not undertaken in strict accordance with the instructions.
- The pump is not installed and operated in accordance with the instructions.
- Necessary repairs are not undertaken by our personnel or are undertaken without our prior written permission.
- Modifications are made to the products supplied without our prior written permission.
- The spare parts used are not original Johnson Pump parts.
- Additives or lubricants used are other than those prescribed.
- The products supplied are not used in accordance with their nature and/or purpose.
- The products supplied have been used amateurishly, carelessly, improperly and/or negligently.
- The products supplied become defective due to external circumstances beyond our control.

All parts which are liable to wear are excluded from guarantee. Furthermore, all deliveries are subject to our "General conditions of delivery and payment", which will be forwarded to you free of charge on request.

1.4 Inspection of delivered items

Check the consignment immediately on arrival for damage and conformity with the advice note. In case of damage and/or missing parts, have a report drawn up by the carrier at once.

1.5 Instructions for transport and storage

1.5.1 Dimensions and weight

A pump or a pump unit is generally too heavy to be moved by hand. Therefore, use the correct transport and lifting equipment. Dimensions and weight of the pump or pump unit are shown on the label on the cover of this manual.

1.5.2 Use of pallets

Usually a pump or pump unit is shipped on a pallet. Leave it on the pallet as long as possible to avoid damages and to facilitate possible internal transport.



When using a forklift always set the forks as far apart as possible and lift the package with both forks to prevent it from toppling over! Avoid jolting the pump when moving it!

1.5.3 Hoisting

When hoisting a pump or complete pump units the straps must be fixed in accordance with figure 1 and figure 2.



When lifting a pump or a complete pump unit always use a proper and sound lifting device, approved to bear the total weight of the load!



Never go underneath a load that is being lifted!



If the electric motor is provided with a lifting eye, this lifting eye is intended only for the purpose of carrying out service activities to the electric motor! The lifting eye is designed to bear the weight of the electric motor only! It is NOT permitted to lift a complete pump unit at the lifting eye of an electric motor!!

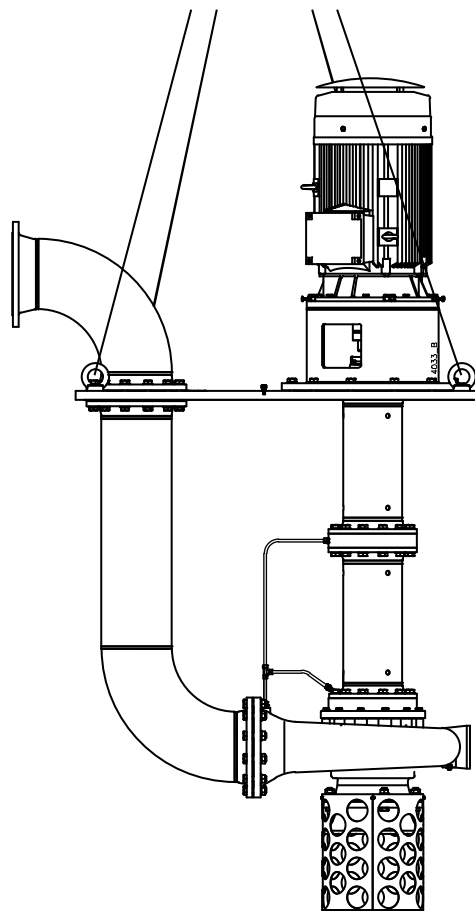

Figure 1: Lifting instructions for pump unit.

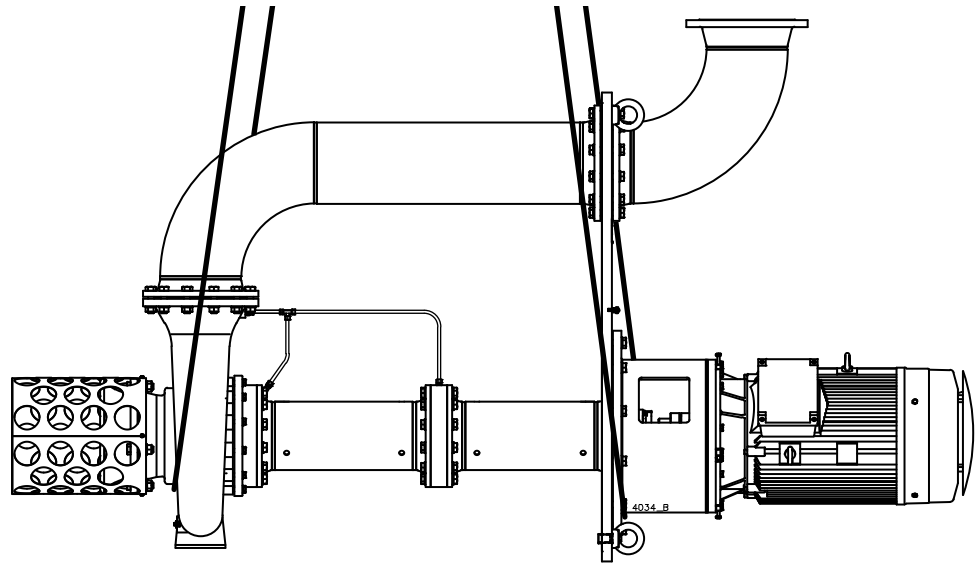

Figure 2: Lifting instructions for single pump.

1.5.4 Storage

If the pump is not to be used immediately the pump shaft must be turned by hand twice per week.

1.6 Ordering parts

This manual contains a survey of the spare parts recommended by Johnson Pump as well as the instructions for ordering them. A fax-order form is included in this manual.

You should always state all data stamped on the type plate when ordering parts and in any other correspondence regarding the pump.

➤ *This data is also printed on the label on the front of this manual.*

If you have any questions or require further information with regard to specific subjects, then do not hesitate to contact Johnson Pump.

2 General

2.1 Pump description

The CombiSump is a range of seal-less centrifugal pumps, with the pump casing submerged into the liquid. The hydraulic field meets EN 733 (DIN 24255) and EN 22858 (DIN 24256/ISO 2858). The CombiSump is part of the CombiSystem. The pump casings and impellers of CombiChem and CombiNorm are the basic parts of these submersible pumps. The pump is driven by a standard IEC flange electric motor. The power is transmitted through a flexible coupling.

2.2 Type code

Pumps are available in various designs. The main characteristics of the pump are shown in the type code.

Example: **CS 40-200 X2 R6 L2 M2 P1**

pump family	CS	CombiSump	
pump size	40 - 200	diameter discharge connection [mm] - nominal impeller diameter [mm]	
execution pump casing	X1	pump casing CombiNorm	
	X2	pump casing CombiChem	
	X3	pump casing HCR	
materials pump casing and impeller	G1	cast iron pump casing	cast iron impeller
	G2	cast iron pump casing	bronze impeller
	R6	stainless steel pump casing	stainless steel impeller
	GS1	cast steel pump casing	cast iron impeller
lubrication slide bearings	L2	liquid lubrication	
shaft sealing	S0	oil baffle	
	S3	gland packing with shaft sleeve and lantern ring	
	M2	unbalanced mechanical seal with shaft sleeve	
delivery connection	P1	vertical PN16	
	P2	vertical PN20 (150 lbs)	
	P3	bend 90° PN16	
	P4	bend 90° PN20 (150 lbs)	

2.3 Serial number

Serial number of the pump or pump unit are shown on the name plate off the pump and on the label on the cover of this manual.

Example: **01-1000675A**

01	year of manufacture
100067	unique number
5	number of pumps
A	pump with motor
B	pump with free shaft end

2.4 Applications

- In general, this pump can be used for thin, clean or slightly polluted liquids. These liquids should not affect the pump materials.
- The maximum allowed system pressure and temperature and the maximum speed depend on the pump type and the pump construction. For relevant data see paragraph 10.4 "Maximum allowable working pressures".
- Further details about the application possibilities of your specific pump are mentioned in the order confirmation and/or in the data sheet enclosed with the delivery.
- Do not use the pump for purposes other than those for which it is delivered without prior consultation with your supplier.



Using a pump in a system or under system conditions (liquid, working pressure, temperature, etc.) for which it has not been designed may hazard the user!

2.5 Construction

2.5.1 Dry part

The pump is driven by an electric motor. The latter is mounted on a lantern piece which rests on the baseplate. The baseplate can be adapted to the size of the pit. The standard version of the baseplate is a rectangular plate for not gas-tight pits, but a round flange shape is also possible, for gas-tight pits. The delivery connection is placed on the baseplate, in a horizontal or vertical position, with flanges according to ISO 7005 PN 16, or ISO 7005 PN 20 (ANSI B16.5 150 lbs).

2.5.2 Submersible part

Below the baseplate the stand pipe is situated, consisting of one or more parts. The stand pipe serves to connect the pump casing with the baseplate, to protect the shaft and to support the possible intermediate bearings. The pump casing is connected with the stand pipe by means of a reducing flange. The stuffing box cover is clamped between the reducing flange and the pump casing. The delivery pipe is placed between the delivery connection on the baseplate and, with a bend, the delivery flange of the pump casing

2.5.3 Pump casing/impeller

Each individual pump type has matching constructions of pump casing and impeller. These parts are available in different material executions which are interchangeable within the pump type because of their equal construction. Principally, with these facts the hydraulic performance is stated. The pumps can be supplied with cast iron or stainless steel pump casings and with cast iron, bronze or stainless steel impellers.

2.5.4 Shaft sealing

At the location of the shaft passage the baseplate is provided with a shaft sealing. Standard this is an oil baffle, but gland packing or a mechanical seal is also possible, for example to prevent harmful odours from emerging into the atmosphere.

2.5.5 Bearing construction

The part above the baseplate (the 'dry' part) is provided with a double-row angular-contact ball-bearing for the pump shaft, for bearing groups 1, 2 and 3. Pumps of bearing group 4 are provided with 2 angular contact ball bearings. In the part below the baseplate (the 'wet' part) the pump shaft is provided with slide bearings. The number of them depends on the length of the pump shaft. The slide bearings are lubricated with the pumped liquid.

2.6 Application area

The application area globally looks as follows:

Table 1: Application area.

	Maximum value
Capacity	1500 m ³ /h
Discharge head	160 m
System pressure	16 bar
Temperature	160 °C

However, the maximum allowable pressures and temperatures depend strongly on the selected materials and components. Also working conditions may cause differences. For more detailed information see paragraph 10.6 "Maximum allowable working pressures".

2.7 Re-use

The pump may only be used for other applications after prior consultation with Johnson Pump or your supplier. Since the lastly pumped medium is not always known, the following instructions should be observed:

- 1 Flush the pump properly.
- 2 Make sure the flushing liquid is discharged safely (environment!)



Take adequate precautions and use the appropriate personal protection means like rubber gloves and spectacles!

2.8 Scrapping

If it has been decided to scrap a pump, the same flushing procedure as described for Re-use should be followed.

3 Installation

3.1 Safety

- Read this manual carefully prior to installation and commissioning. Non-observance of these instructions can result in serious damage to the pump and this will not be covered under the terms of our guarantee. Follow the instructions given step by step.
- Ensure that the pump can not be started if work has to be undertaken to the pump during installation and the rotating parts are insufficiently guarded.
- Depending on the design the pumps are suitable for liquids with a temperature of up to 160°C. When installing the pump unit to work at 70°C and above the user should ensure that appropriate protection measures and warnings are fitted to prevent contact with the hot pump parts.
- If there is danger of static electricity, the entire pump unit must be earthed.
- If the pumped liquid is harmful to men or the environment, take appropriate measures to drain the pump safely. Possible leakage liquid from the shaft seal should also be discharged safely.

3.2 Environment

- The foundation must be hard, level and flat.
- The area in which the pump is installed must be sufficiently ventilated. An ambient temperature or air humidity which is too high, or a dusty environment, can have a detrimental effect on the operation of the electric motor.
- There should be sufficient space around the pump unit to operate and if necessary repair it.
- Above the cooling air inlet of the motor there must be a free area of at least ¼ of the electric motor diameter, to ensure unobstructed air supply.

3.3 Mounting

3.3.1 Assembling a pump unit

If the pump and the electric motor still have to be assembled, proceed as follows:

- 1 Fit the coupling half (7060) to the pump shaft. Push it against the shaft shoulder and tighten the locking screw by hand.
- 2 Fit the coupling half (7040) to the motor shaft. The end of the coupling half must be lined up with the end of the motor shaft.
- 3 Place the electric motor on the lantern piece. Use the positioning screws (7036) to center the electric motor.
- 4 Secure the electric motor with bolts (4010) and nuts (4020). Fit washers (4025) between bolts and lantern piece.

3.3.2 Placing a pump unit

➤ *When a complete pump unit is supplied, in the factory the coupling halves at pump side is fitted to the shaft resting on the shaft shoulder and the locking screw is tightened by hand.*

- Place the pump onto the pit. Place the pump in exact vertical position. Therefore align the baseplate on the foundation exactly level and stress-free.

3.4 Connecting the electric motor



The electric motor must be connected to the mains by an approved electrician, according to the locally prevailing regulations of the electricity company.

- Refer to the instruction manual belonging to the electric motor.
- If possible, mount a working switch as close as possible to the pump.

3.5 Checking the sense of rotation

- 1 The sense of rotation of the pump is indicated by an arrow. Check whether the sense of rotation of the motor corresponds with that of the pump.



Checking the sense of rotation of the electric motor must absolutely be done only with disconnected coupling halves! Even rotating very shortly in the wrong direction can cause irreparable damage to the pump!

- 2 Let the motor run for only a short time and check the sense of rotation. Beware of possible non-screened rotating parts, when checking the sense of rotation!
- 3 If the sense of rotation is **not** correct, change the sense of rotation. See the instructions in the user manual belonging to the electric motor.

3.6 Fitting the coupling

- 1 Loosen the locking screw of the coupling half on the pump shaft.
- 2 Fit the coupling halves on the pump shaft in the correct position. There must be a gap of **3 mm** between the coupling halves.
- 3 Tighten the locking screw.

3.7 Alignment of the coupling

- 1 Place a ruler (A) on the coupling. The ruler should touch both coupling halves across the whole width. See figure 3. Do this check on 3 spots around the coupling.
- 2 Check for a possible angular deviation, using a pair of outside calipers (B) at 2 corresponding points of the side surfaces of the coupling halves. See figure 3. Do this check on 3 spots around the coupling.



An angular deviation basically must not occur! In the event an angular deviation is verified, this indicates an inclusion between motor flange and lantern piece! Remove the electric motor and clean the fitting edges!

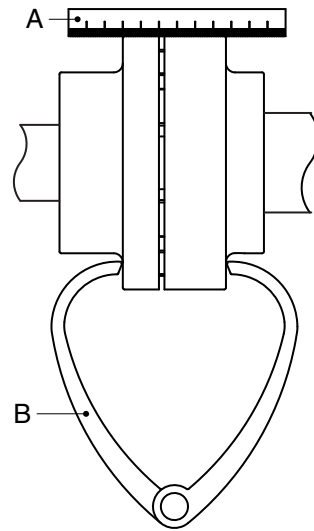

Figure 3: Aligning the coupling by means of a ruler and a pair of outside calipers.

- 3 The alignment is correct if the measured values are within the tolerance limits, see figure 4 and the corresponding table.

If the alignment is not correct move the electric motor:

- 4 Partially loosen bolts (4010).
- 5 Move the electric motor, using positioning screws (7036).
- 6 Check the alignment of the coupling, as described in paragraph 3.7 "Alignment of the coupling".
- 7 When the alignment is correct, tighten bolts (4010) and nuts (4020).



After any alignment action (check or readjustment): Fit the guard!

3.7.1 Tolerances for aligning the coupling

The maximum allowable tolerances for the alignment of the coupling halves are shown in Table 2. See also figure 4.

Table 2: Alignment tolerances

External diameter of coupling [mm]	V		Va _{max} - Va _{min} [mm]	Vr _{max} [mm]
	min [mm]	max [mm]		
81-95	2	4	0,15	0,15
96-110	2	4	0,18	0,18
111-130	2	4	0,21	0,21
131-140	2	4	0,24	0,24
141-160	2	6	0,27	0,27
161-180	2	6	0,30	0,30
181-200	2	6	0,34	0,34
201-225	2	6	0,38	0,38

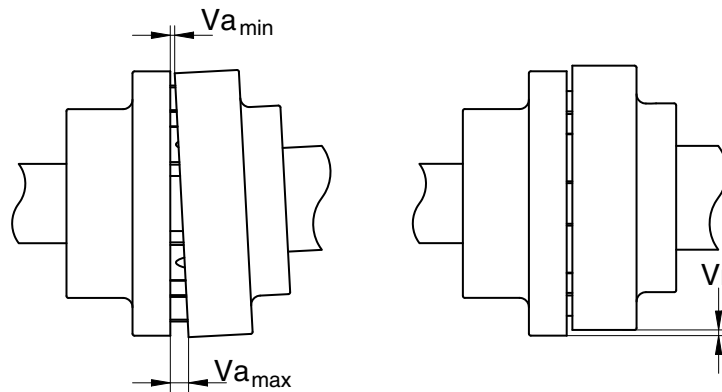

Figure 4: Alignment tolerances standard coupling.

3.8 Piping

- The piping to the suction and delivery connections must fit exactly and must not be subject to stress during operation. .
- Fit any parts that may have been supplied separately.
- In case of a pump with an external flushing system for stuffing box (S3) or mechanical seal (M2), connect the flushing chamber to that flushing system.

4 Commissioning

4.1 Inspection of the pump

- Construction with stuffing box packing: check whether the nuts (2050) have not been over tightened. If necessary, loosen these nuts and tighten them again by hand.
- Check whether the pump shaft turns freely. Do this by turning the shaft end at the coupling a few times by hand.
- Check whether the fuses have been mounted.

4.2 Liquid level

A sufficiently high liquid level is required to ensure proper operation of the pump. If the liquid level is too low, air may be aspirated. The so-called "vortex effect" then occurs, which not only affects the performance of the pump, but can also seriously damage the pump as a result of vibrations, cavitation or insufficient lubrication of the slide bearings. The "vortex effect" occurs when the suction speed in the pump is so high that strong vortices occur in the liquid. See chapter 10 for the minimum required liquid level, dependent of the operational circumstances.



Depending on pit pressure, vapour pressure, temperature, sump depth, etc., NPSH available at the pump casing suction flange must always exceed the NPSH required for the pump!

4.3 Preparing the unit for commissioning

Proceed as follows, both when the unit is put into operation for the first time and after the pump has been overhauled:

- Connect the supply piping in case the shaft sealing is being flushed with a clean external flushing liquid.

4.4 Starting the pump

- 1 Open the stop valve in the supply piping for flushing liquid, if the pump is supplied with a flushing system.
- 2 Close the delivery stop valve and start the pump.
- 3 As soon as the pump is under pressure, slowly open the delivery stop valve until the working pressure is attained.



Make sure that when a pump is running, rotating parts are always properly screened off by the protective guards!



The pump should never run dry!

4.5 Adjustment of shaft sealing

4.5.1 Stuffing box packing

After the pump is started, the stuffing box packing will show a certain amount of leakage. Because of the expansion of the packing fibres, this leakage will gradually decrease. Make sure that the stuffing box packing never runs dry. To prevent this, loosen the nuts (2050) to the extent that the stuffing box packing leaks by drops. As soon as the pump has reached the proper temperature (and leakage is still too much) the gland can be adjusted permanently:

- 1 Tighten both nuts, one after the other, a quarter turn.
- 2 Wait 15 minutes after each adjustment before making the next adjustment.
- 3 Continue in this way until an acceptable leakage by drops has been attained (10/20 cm³/h).
- 4 Fit the guard (7110).

4.5.2 Mechanical seal

- A mechanical seal may never show visible leakage.

4.6 Noise

The noise production of a pump depends to a great extent on the operating conditions. The values stated in paragraph 10.8 "Noise data" are based on normal operation of the pump, driven by an electric motor. In case the pump is driven by a combustion engine, or in case it is used outside the normal operation area, as well as in case of cavitation, the noise level may exceed 85 dB(A). In that case precautions should be taken, like building a noise-barrier around the unit or wearing hearing protection.

5 Maintenance

5.1 Daily maintenance

Regularly check the outlet pressure.



No water should get into the terminal box of the electric motor when the pump room is sprayed clean!

Never spray water on hot pump parts! The sudden cooling down may cause them to burst and hot water may flow out!



NEVER spray any water on the seals of the bearings when spraying clean the pump or the pump room. Ensure no water comes into contact with grease!

5.2 Shaft sealing

5.2.1 Stuffing box packing

Do not tighten the nuts (2050) any more after the running-in period and adjustment. If in time the stuffing box packing starts to leak excessively, new packing rings have to be mounted instead of further tightening the nuts!

5.2.2 Mechanical seal

A mechanical seal generally requires no maintenance, however, **it should never be allowed to run dry**. If there are no problems, do not dismantle the mechanical seal. As the seal faces have run in on one another dismantling usually implicates replacement of the mechanical seal. If a mechanical seal shows any leakage it has to be replaced.

5.2.3 Flushing liquid

Check the pressure of the flushing liquid regularly.

5.3 Lubrication of the bearings

The double-row angular contact ball-bearing requires re-greasing **after every 6000 hours of operation**. The bearing is filled with grease during assembly. In case the pump is overhauled, the bearing house and the bearings have to be cleaned and provided with new grease. See chapter 10 for recommended greases. However it is advised to mount a new ball bearing when the pump is overhauled.

5.4 Environmental influences

- Regularly clean the filter in the suction pipe or the suction strainer at the bottom of the suction pipe, as the inlet pressure may become too low if the filter or the suction strainer is fouled.
- If there is a risk that the pumped liquid expands during solidification or freezing, the pump has to be drained and, if necessary, flushed after it has been put out of service.
- If the pump is out of service for a long time, it has to be preserved and stored on a vibration-free foundation.

5.5 Noise

If a pump starts making noise, this may point to certain problems with the pump unit. A crackling noise can indicate cavitation or excessive motor noise can indicate deterioration of the bearings.

5.6 Faults



The pump, of which you want to determine the fault, may be hot or under pressure. Take the appropriate precautions first and protect yourself with the proper safety devices (safety goggles, gloves, protective clothing)!

To determine the source of the malfunctioning of the pump, proceed as follows:

- 1 Switch off the power supply to the pump unit. Lock the working switch with a padlock or remove the fuse. In case of a combustion engine: switch off the engine and close the fuel supply to the engine.
- 2 Close the stop valves.
- 3 Determine the nature of the fault.
- 4 Try to determine the cause of the fault with chapter 6 "Problem solving" and take the appropriate measures or contact your installer.

6 Problem solving

Faults in a pump installation can have various causes. The fault may not be in the pump, it may also be caused by the pipe system or the operating conditions. Firstly, always check that installation has been executed in accordance with the instructions in this manual and that the operating conditions still correspond with the specifications for which the pump was purchased.

In general, breakdowns in a pump installation are attributable to the following causes:

- Faults with the pump.
- Breakdowns or faults in the pipe system.
- Faults due to incorrect installation or commissioning.
- Faults due to incorrect choice of pump.

A number of the most frequently occurring failures as well as their possible causes are shown in the table below.

Table 3: Most frequently occurring failures.

Most common faults	Possible causes, see Table 4.
Pump delivers no liquid	1 2 5 9 11 13 14 17 19 20 21 29
Pump has insufficient volume flow	1 2 5 9 11 13 14 15 17 19 20 21 28 29
Pump has insufficient head	2 4 5 13 14 17 19 28 29
Pump stops after start up	1 2 5 9 11
Pump has higher power consumption than normal	12 15 16 17 18 22 23 24 25 26 27 32 34 38 39
Pump has lower power consumption than normal	13 14 15 16 17 18 20 21 28 29
The stuffing box packing is leaking excessively	23 25 26 30 32 33
Packing rings or mechanical seal have to be replaced to often	23 25 26 30 32 33 34 36 41
Pump vibrates or is noisy	1 9 11 15 18 19 20 22 23 24 25 26 27 28 29 37 38 39
Bearings wear too much or become hot	23 24 25 26 27 37 38 39 42
Pump running rough hot or seizes	23 24 25 26 27 34 37 38 39 42
Slide bearings wear too much	23 24 25 26 27 28 29 38 44 46 47
Slide bearings got stuck	46 47

Table 4: Possible causes of pump failures.

	Possible causes
1	Pump casing not sufficiently submerged (see mp in dimensions drawing)
2	Gas or air coming from the liquid
5	The pump sucks in air through the lowest slide bearing
9	Suction pipe or suction strainer is blocked
11	NPSH available too low
12	Speed too high
13	Speed too low
14	Wrong sense of rotation
15	Pump does not operate at the right duty point
16	Liquid density differs from the calculated liquid density
17	Liquid viscosity differs from the calculated liquid viscosity
18	Pump operates when the liquid flow is too low
19	Wrong pump selection
20	Obstruction in impeller or pump casing
21	Obstruction in the piping
22	Wrong installation of the pump unit
23	Pump and motor not well aligned
24	Rotating part running out of true
25	Imbalance in rotating parts (for instance: impeller, coupling or pump shaft)
26	Pump shaft is oscillating
27	Bearings faulty or worn out
28	Wear ring faulty or worn out
29	Damaged impeller
30	Shaft sleeve at shaft packing or sliding faces of the mechanical seal are worn out or damaged
32	Not well packed stuffing box packing or bad mounting of the mechanical seal
33	Stuffing box packing type or mechanical seal not suitable for the pumped liquid or operation circumstances
34	Gland or mechanical seal cover has been tightened too much or crookedly
36	Quenching or flushing liquid to the packing rings or the mechanical seal is polluted
37	Axial retaining of impeller or pump shaft is defective
38	The bearings have been mounted wrongly
39	Too much or too little bearing lubrication
41	Impurities in the liquid get into the stuffing box packing
42	Too high axial force because of worn dorsal blades or excessive inlet pressure
44	Delivery pipe is not mounted stress-free
46	Too little bearing lubrication
47	Liquid supply pipe to slide bearing not connected or blocked

7 Disassembly and assembly

7.1 Precautionary measures



Take adequate measures to avoid that the motor is started while you are working on the pump. This is especially important for electric motors with remote control:

- Switch the operating switch near the pump (if available) to "OFF".
- Switch off the pump switch on the switchboard.
- If necessary remove the fuses.
- Hang a danger board near the switchboard cabinet.

7.2 Special tools

Assembly and disassembly work requires no special tools. However, such tools can make certain jobs easier, for instance replacing the shaft seal. If such is the case it will be indicated in the text.

7.3 Designation of parts

7.3.1 Position numbers

The position numbers used in the descriptions below refer to the figures shown in the description. These numbers are also used in the general cross section drawings and the corresponding parts lists in chapter 9.

7.3.2 Constructive variants

The pumps can be supplied in various constructive variants. Each variant has a code which is stated in the type identification on the name plate on the pump

Shaft sealing	oil catcher	S0
	stuffing box packing	S3
	mechanical seal	M2
Delivery connection	vertical PN 16	P1
	vertical PN 20 (150 lbs)	P2
	bend 90° PN 16	P3
	bend 90° PN 20 (150 lbs)	P4

7.4 Dismantling

7.4.1 Disconnection of the pump unit

- 1 Close the stop valve in the delivery pipe.
- 2 Open the cover of the junction box on the motor. Disconnect the supply wires. Mark the wires and the corresponding connection points for easy reconnection.
- 3 Loosen the bolts of the delivery flange and the base plate (6000) and lift the pump out of the pit, using the crane hooks (6170). Drain the pump completely.

7.4.2 Liquid draining



Wet pit pumps are usually used for pumping polluted liquids and/or liquids that are harmful to the environment. Therefore it is important you wear protective gloves and glasses!

- 1 Leave the pump hanging over the pit and drain it further through the drain plug (1310).
- 2 Flush the pump properly. Clean the outside of the plunging element very well.
- 3 Then put back the drain plug.



Ensure no liquid gets into the environment.

7.5 Disassembly

7.5.1 Disassembly of the delivery pipe

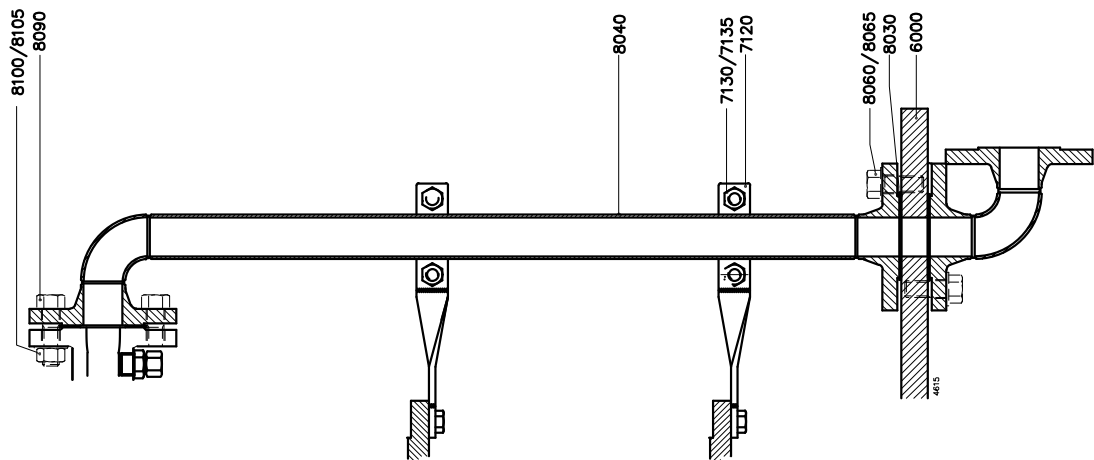

Figure 5: Disassembly of the delivery pipe.

- 1 Place the base plate (6000) before disassembly in a supporting structure and support the stand pipe at some places so as to keep it horizontal.
- 2 Loosen the bolts (8090) and nuts (8100).
- 3 Loosen the tap bolts (8060).
- 4 Remove the delivery pipe (8040) and the gaskets (8030).

7.5.2 Disassembly of the electric motor

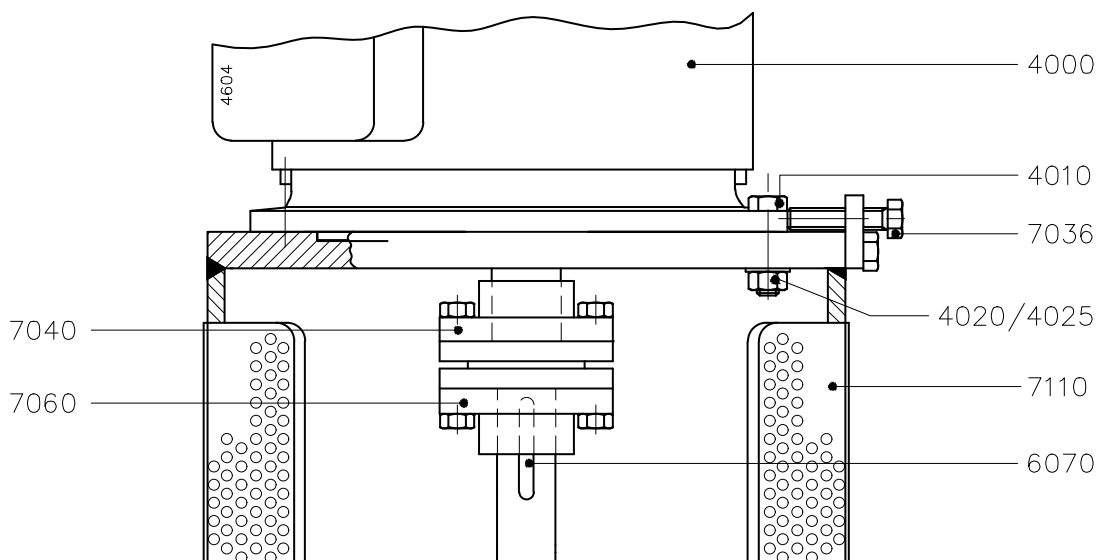

Figure 6: Disassembly of the electric motor.

- 1 Remove the guard (7110).
- 2 Disassemble the electric motor (4000) by loosening the motor fixing bolts (4010).
- 3 Disassemble the coupling half (7060) and remove the coupling key (6070).

- 5 Loosen the Allen screws (2110) and remove the seal chamber (2100).
- 6 Remove the packing rings (2010) and the lantern ring (2020).
- 7 Remove the gasket (2170).

7.5.5 Replacement gland packing shaft sealing group S3

- 1 Loosen the gland nuts (2050) and pull the gland (2030) as far as possible backward.
- 2 Remove the packing rings (2010) and the lantern ring (2020). Your supplier can supply you with a special puller to remove the old packing rings.
- 3 Clean the packing space properly and make sure the shaft sleeve has not worn in. If it has, it also should be replaced, see paragraph 7.5.4 "Disassembly shaft sealing group S3".

7.5.6 Disassembly mechanical seal M2

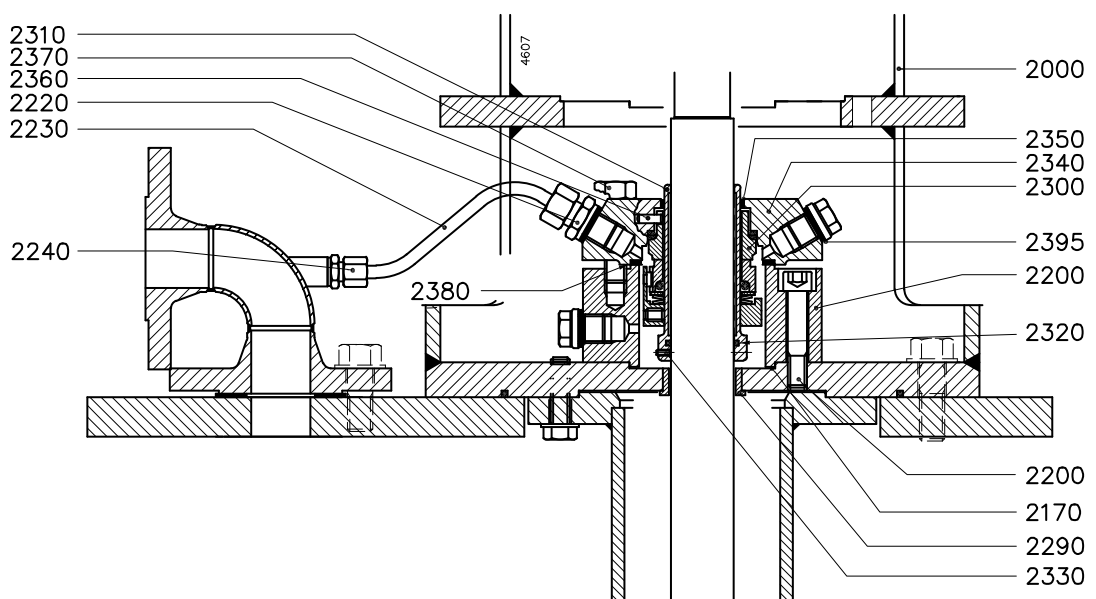

Figure 9: Mechanical seal M2.

- 1 Remove the ball-bearing, see paragraph 7.5.3 "Disassembly ball bearing".
- 2 Loosen the screw couplings (2220 and 2240) and remove the pipe (2230).
- 3 Loosen the tap bolts (2370) and remove the cover (2340) of the mechanical seal, including the stationary part of the mechanical seal (2300) and the throttling bush (2350).
- 4 Remove the gasket (2380).
- 5 Loosen the Allen screws (2210) and remove the seal chamber (2200) and the gasket (2170).
- 6 Loosen the set screw of the rotating part of the mechanical seal (2300) and remove this part.
- 7 Loosen the 3 set crews (2330) of the shaft sleeve (2310) and remove the shaft sleeve.
- 8 Check the throttling bush (2290) in the lantern piece (2000). If the play to the diameter is excessive, the throttling bush should be replaced. Fix the new throttling bush with Loctite 641.

7.5.7 Disassembly pump casing/impeller

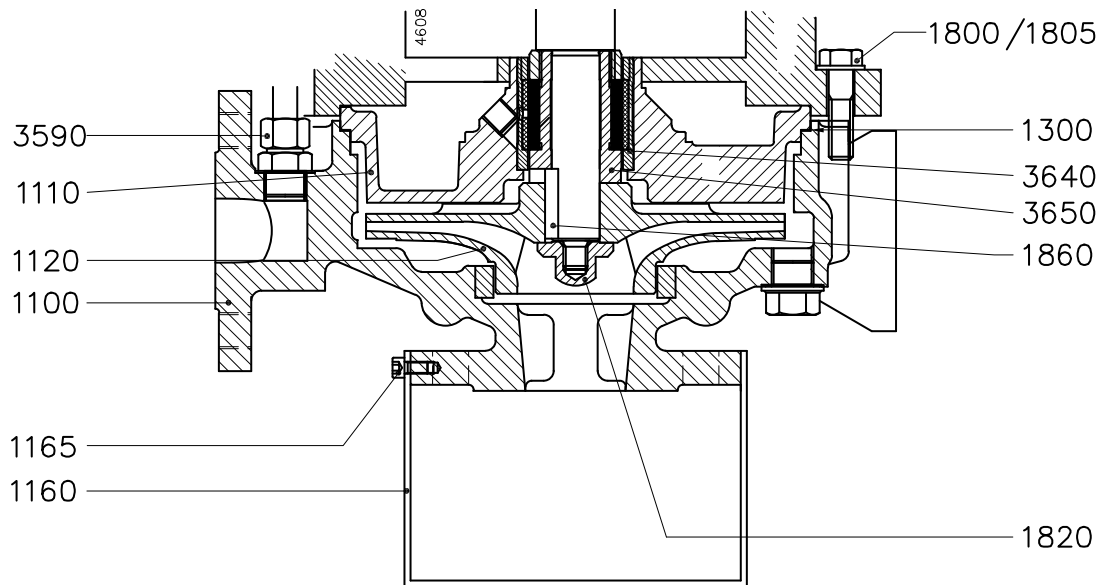

Figure 10: Pump casing/impeller.

- 1 Remove the delivery pipe, see paragraph 7.5.1 "Disassembly of the delivery pipe".
- 2 Remove, if there, the suction strainer (1160) by loosening bolts (1165).
- 3 Loosen the pipe coupling (3590).
- 4 Loosen the bolts (1800) and remove the pump casing (1100).
- 5 Block the impeller (1120) and loosen the impeller nut (1820).
- 6 Remove the impeller and the impeller key (1860).

7.5.8 Disassembly pump shaft

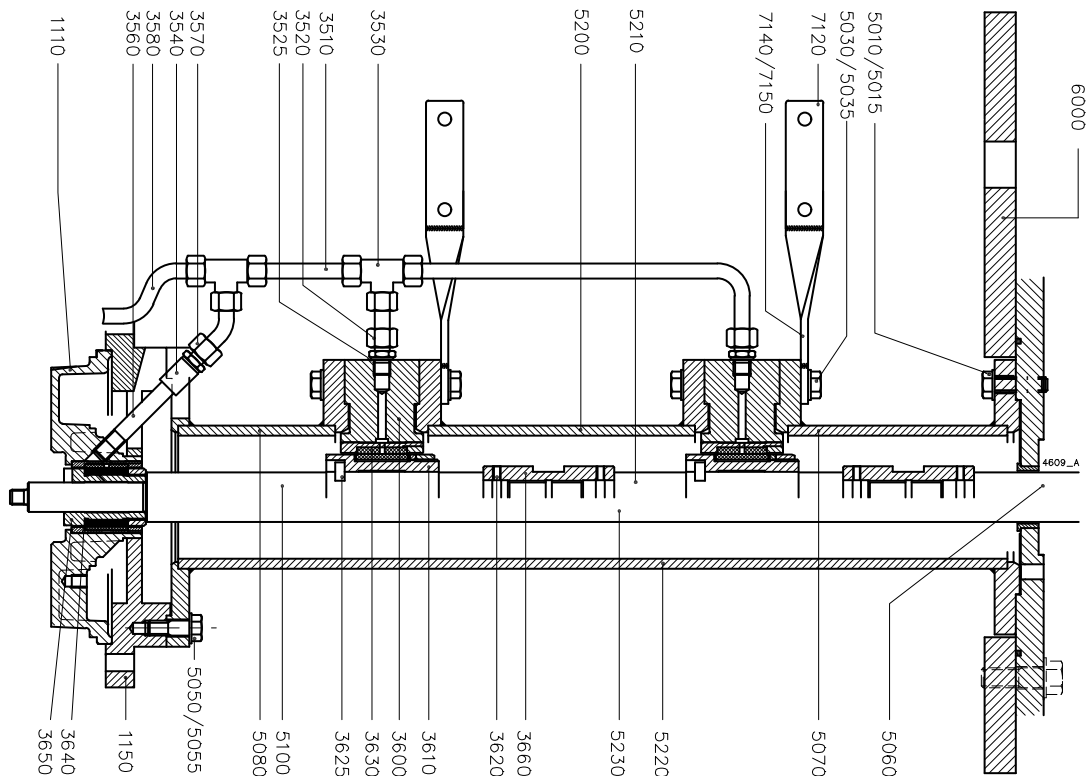

Figure 11: Pump shaft with intermediate bearing.

- 1 Loosen the screw couplings (3520 and 3570) and remove the complete pipe (3510 + 3580).
- 2 Remove the pipe (3560) from the stuffing box cover (1110).
- 3 Remove the stuffing box cover.
- 4 Remove the slide bearing sleeve (3650).
- 5 Remove the pump shaft (5230, or 5060+5100, or 5060+5100+5210).
- 6 Loosen the bolts (5050) and remove the reducing flange (1150).
- 7 Inspect the slide bearing (3640). If it is damaged, it should be replaced.
- 8 In case the pump is provided with intermediate bearings: Loosen the set screws (3620) and unscrew the shaft parts. Remove the coupling sleeve(s) (3660) from the shaft ends. Remove the slide bearing sleeve(s) (3610) and the pin(s) (3625).

7.5.9 Disassembly standpipes and intermediate bearings

- 1 Provide the flanges of the standpipes and the intermediate bearings (3600) in between with durable marks, e.g. by means of letter stamps, centre punch or scribe. This way the parts can be put back in the same position and without having to readjust them.
- 2 Loosen the tap bolts (5010) and remove the entire standpipe (5220, or 5070+5080, or 5070+5080+5200).
- 3 Loosen the bolts (5030) and the nuts (5040) and pull the standpipe parts apart in axial direction.
- 4 Check the slide bearings. Damaged slide bearings should be replaced.

7.5.10 Disassembling the wear ring

When the pump casing has been disassembled the wear ring can be removed. In most cases the ring has been fixed so tightly that it cannot be removed undamaged.

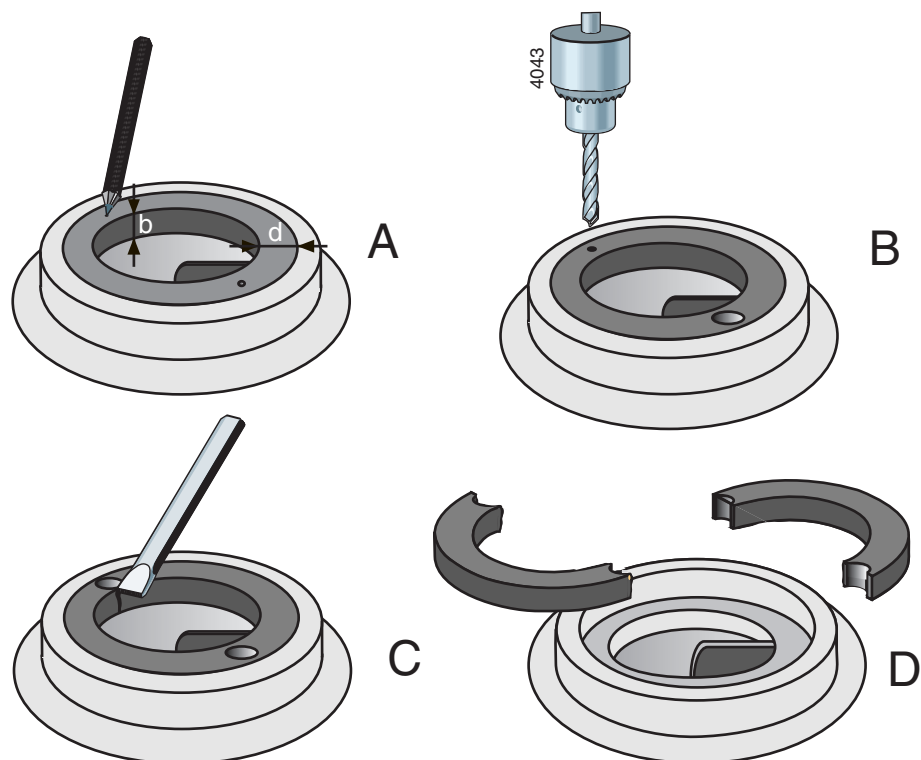

Figure 12: Removal of wear ring.

- 1 Measure the thickness (d) and the width (b) of the ring, see figure 12 A.
- 2 Make a centre hole in the middle of the edge of the ring at two opposite points, see figure 12 B.
- 3 Use a drill with a diameter just a little bit smaller than the thickness (d) of the ring and drill two holes in the ring, see figure 12 C. Don't drill deeper than the width (b) of the ring. Take care not to damage the fitting edge of the pump casing.
- 4 Use a chisel to cut the remaining part of the ring thickness. Now you can remove the ring in two parts from the pump casing, see figure 12 D.
- 5 Clean the pump casing and carefully remove all bore dust and metal splinters.

7.5.11 Assembling the wear ring

- 1 Clean and degrease the fitting edge of the pump casing where the wear ring is to be mounted.
- 2 Degrease the outer edge of the wear ring and put a few drops of Loctite 641 on it.
- 3 Fit the wear ring in the pump casing. **Take care it is not pushed out of alignment!**

7.6 Assembly of the submersible part without intermediate bearings

7.6.1 Conventions

The CombiSump is assembled in horizontal position. Terms like bottom, top, front and back side are always used in relation to the working surface.

7.6.2 Preparation of the submersible part without intermediate bearings

Check the shaft (5230, or 5060+5100 or 5060+5100+5210) on runout. The runout should not be more than 0,08 mm, when the shaft is resting on the slide bearings.

7.6.3 Assembly of shaft and standpipe without intermediate bearings

See figure 7 for explanation of the item numbers.

- 1 Support the shaft on rolls. Then measure runout at the shaft sleeve and at the ball bearing. The runout should not be more than 0,08 mm.
- 2 Fit the slide bearing sleeve (3650) and the impeller key (1860).
- 3 Assemble the base plate (6000) and the lantern piece (2000) with tap bolts (6140). Place washers (6145) under the bolt heads. In case of a gas proof version, mount gaskets as well.
- 4 Press the slide bearing (3640) into the bore of the stuffing box cover (1110). This should not require great force.
- 5 Fit the standpipe (5220) to the supporting flange with bolts (5010). Place washers (5015) under the bolt heads
- 6 Slide the entire shaft inside.
- 7 If provided, mount the adapter flange (1150). Looking at it from drive side the slot must be located at the left.
- 8 Mount the stuffing box cover (1110) with the lubrication connection towards the slot in the standpipe.
- 9 Fit the impeller (1120) with the cap nut (1820).

7.7 Assembly of submersible part with intermediate bearings

See figure 7, figure 8 and figure 9 for explanation of the item numbers.

7.7.1 Preparation submersible part with intermediate bearings

- Check the shaft parts (5060, 5100, 5210) on runout. The runout should not be more than 0,08 mm.

7.7.2 Assembly shaft with intermediate bearings

- 1 Fit a pin (3625) into shaft part (5100) and mount a slide bearing sleeve (3610) onto the shaft part.
- 2 Put some "Never Seez" anti-seize paste (see chapter 10) on the thread of the shaft part. Screw a coupling sleeve (3660) onto the end of the shaft part.
- 3 Put some "Never Seez" anti-seize paste on the thread of the next shaft part and screw it into the coupling sleeve (3660).
- 4 In case the pump has 2 intermediate bearings: Fit a pin (3625) into shaft part (5210) and mount the other slide bearing sleeve (3610) onto the shaft part.
- 5 Mount the last coupling sleeve and shaft part together as described above.
- 6 Lock all the coupling sleeves with the set screws (3120).
- 7 Support the shaft at several points on rolls. Then measure the runout at the coupling sleeves, the shaft sleeve and the ball bearing (6110). The runout should not be more than 0,08 mm.

7.7.3 Assembly standpipe with intermediate bearings

- 1 Assemble the base plate (6000) and the lantern piece (2000) with tap bolts (6140). Place washers (6145) under the bolt heads. In case of a gas proof version, mount gaskets as well.
- 2 Fit the O-ring (2160).
- 3 Fit the slide bearing sleeve (3650) and the impeller key (1860).
- 4 Fit the oil baffle (6060) into its seat and fit the bearing support (6130) with tap bolts (6120). Place washers (6125) under the bolt heads.
- 5 If possible, heat the intermediate bearing housings (3100) up to 180<198>C. Then press the slide bearing bushes (3130 and 3150) into the appropriate fits. This should not require great force.
- 6 Fit the first standpipe (5070) to the supporting flange with bolts (5010). Place washers (5015) under the bolt heads.
- 7 Mount an intermediate bearing (3600) with bolts (5030). The threaded hole for the pipe nipple (3520) must face the side of the delivery pipe. Place washers (5035) under the bolt heads. Mount strips (7140/7150) at the side of the delivery pipe.
- 8 Push the entire shaft inside. Be careful not to damage the slide bearings.
- 9 In case the pump has more than one intermediate bearing: Mount the other standpipe(s) (5200) and intermediate bearing(s) (3600) in the way described above.
- 10 Mount the last standpipe (5080). Looking at it from drive side the slot must be located at the left.
- 11 If provided, mount the adapter flange (1150). Looking at it from drive side the slot must be located at the left.
- 12 Mount the stuffing box cover (1110) with the lubrication connection towards the slot in the standpipe.
- 13 Fit the pipe (3560).
- 14 Fit the complete pipe (3510+3580) and tighten the screw couplings (3520+3570).
- 15 Mount the impeller (1120) with the cap nut (1820).

7.8 Assembly shaft sealing group S3

See figure 8 and figure 11 for explanation of the item numbers.

- 1 Fit the gasket (2170) and mount the seal housing (2100) with Allen screws (2110). Fit the studs (2040).
- 2 Fit the packing rings (2010) and the lantern ring (2020). Press each packing ring down with a matching piece of pipe. Make sure the ring grooves are placed at an angle of 90° in relation to each other.
- 3 Fit the O-ring (2070) in the shaft sleeve (2060) and slide the gland (2030) around the shaft sleeve.
- 4 Mount the shaft sleeve, with the shoulder upwards. Keep the end of the shaft sleeve equal to the bottom of the lantern flange, then pull it 1 mm up and lock it with set screw (2080).
- 5 Press the gland against the last ring and tighten the gland nuts (2050) in turn by hand.

7.9 Assembly shaft sealing group M2

See figure 9 and figure 11 for explanation of the item numbers.

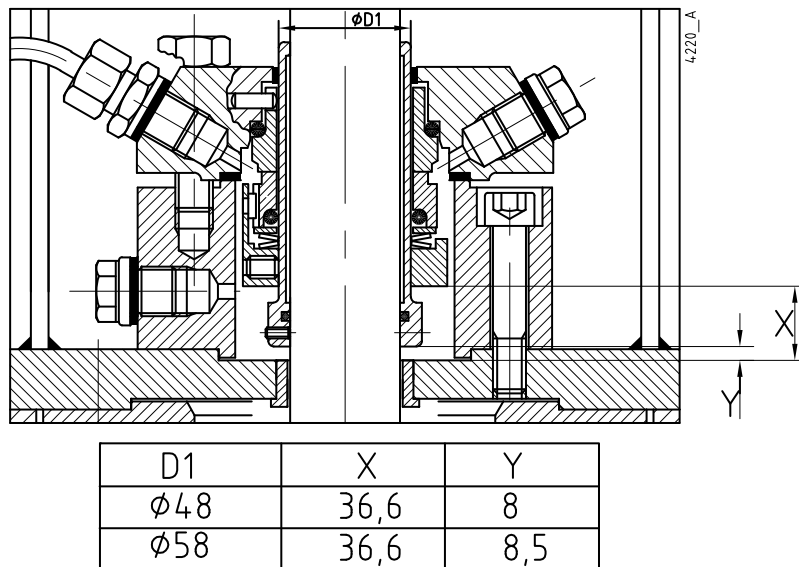

Figure 13: Mounting of the mechanical seal M2.

- 1 Fit the throttling bush (2290) into the lantern piece (2000), applying Loctite 641.
- 2 Fit the O-ring (2320) in the shaft sleeve (2310) and mount the shaft sleeve, with the shoulder downward. The distance between the shaft sleeve and the lantern flange should be set according to distance Y, see figure 14. Secure the shaft sleeve with the set screws (2330).
- 3 Push the rotating part of the mechanical seal (2300) onto the shaft sleeve.
The O-ring should not roll along the shaft sleeve! Put some glycerine or silicon spray on it before you fix it.
- 4 The distance from the shaft sleeve shoulder to the rotating part of the mechanical seal should be according to distance X, see figure 14. Then lock the rotating part of the mechanical seal with the set screw.
- 5 Place the gasket (2170) and fit the seal housing (2200) with Allen screws (2210).
- 6 Fit the locking pin (2360) into the cover (2340) of the mechanical seal.
- 7 Put the cover of the mechanical seal flat down and press the counter-ring of the mechanical seal straight into it. If necessary use a plastic pressure piece.
Never knock it inside! The slot in the counter-ring should coincide with the locking pin in the cover, otherwise the counter-ring will break!
- 8 Fit the gasket (2380) and mount the cover of the mechanical seal with the bolts (2370).
- 9 Mount possible plugs and pipe couplings.

7.10 Assembly of the ball bearing

See figure 7 for explanation of the item numbers.

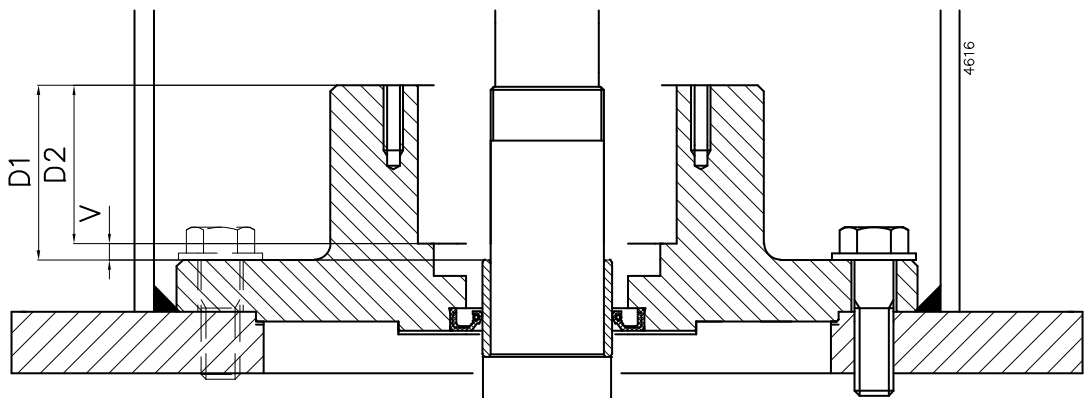

Figure 14: Determining the thickness of the shim rings.

- 1 Place the oil catcher (6060) in the seat and mount the bearing house (6130) with tap bolts (6120). Place washers (6125) under the bolt heads.
- 2 Place a feeler gauge of 0,5 mm between the back vanes of the impeller and the stuffing box cover. Fix the impeller against the stuffing box cover, using clamps.
- 3 See figure 14. Take a depth gauge and measure the distance **D1** from the top of the bearing house to the top of the inner ring and the distance **D2** from the top of the bearing house to the bottom of the ball bearing seat. Fill the difference **V** up with shimming rings (6050).
- 4 Fit the ball bearing (6110) and mount the locking ring (6105) and the bearing nut (6100). Tighten the bearing nut. To lock the check nut, knock one tab of the retaining locking into the opening of the bearing nut.
- 5 Fit the spacer ring (6090).
- 6 Mount the bearing cover (6080) with a new oil catcher (6020). The grease nipple (6030) should point to the right.
- 7 **Remove the feeler gauge!**

7.11 Assembly of the lantern piece with the electric motor

See figure 6 for explanation of the item numbers.

- 1 Fit the key (6070) in the shaft and mount the coupling half (7060) onto the shaft.
- 2 Mount the other coupling half (7040) on the electric motor shaft and place the electric motor on the flange, the junction box in the correct position.
- 3 Align the electric motor according to the instructions in paragraph 3.7 "Alignment of the coupling".

7.12 Mounting the delivery pipe

- 1 Fit the pump casing (1100) and, if there, the suction strainer (1160).
- 2 Fit the flange of the delivery pipe together with the gasket (8030) to the base plate.
- 3 Fit the flange of the delivery pipe together with the gasket (8030) to the pump casing.



The delivery pipe should always be mounted stress-free!

- 4 If the pump has intermediate bearings: Fit the pipe fasteners (7120) with bolts (7130) and nuts (7135).
- 5 Mount the straight delivery pipe (8010), or the 90° bent delivery pipe (8020) including gasket (8035) with the fixing bolts (8070).
- 6 Versions S3 and M2: Mount the flushing pipe (2130 or 2230).

8 Dimensions

For dimension see data sheet enclosed with the delivery.

9 Parts

9.1 Ordering parts

9.1.1 Order form

You can use the order form included in this manual for ordering parts.

When ordering parts always quote the following data:

- 1 Your **address**.
- 2 The **quantity, the item number and the description** of the part.
- 3 The **pump number**. The pump number is stated on the label on the cover of this manual and on the type plate of the pump.
- 4 In the event of different electric motor voltage you should state the correct voltage.

9.1.2 Recommended spare parts

Parts marked with a * are recommended spare parts.

9.2 Pump with shaft sealing group S0

9.2.1 Sectional drawing

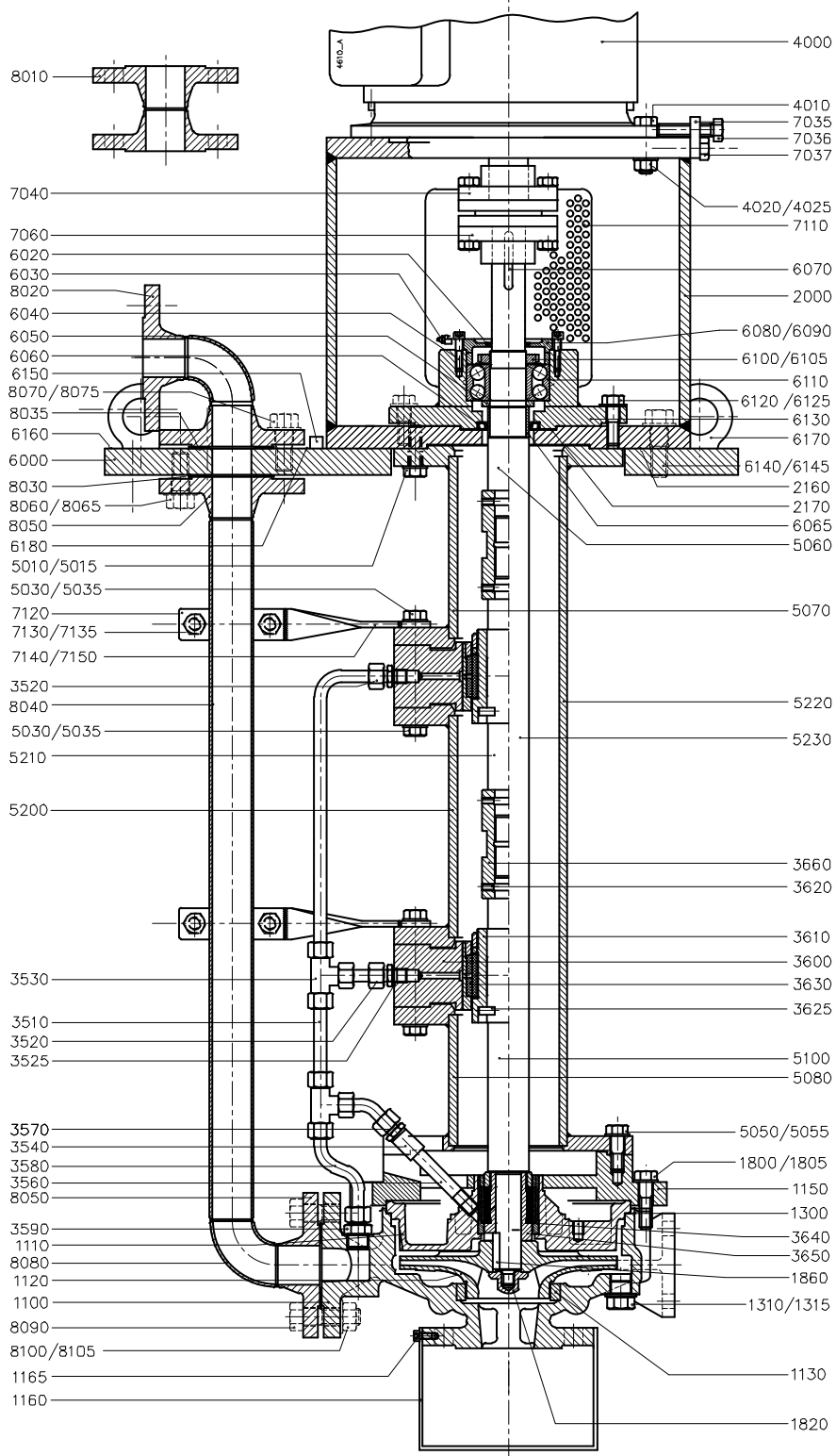

Figure 15: Pump with shaft sealing group S0.

9.2.2 Parts list
See figure 15.

Item Nr.	Quantity			Description	Materials		
	A	B	C		G1	G2	R6
1100	1	1	1	pump casing	cast iron		stainless steel
1110	1	1	1	stuffing box cover	cast iron		stainless steel
1120 *	1	1	1	impeller	cast iron	bronze	stainless steel
1130 *	1 ¹⁾	1 ¹⁾	1 ¹⁾	wear ring	cast iron	bronze	stainless steel
1150	1	1	1	reducing flange	steel		stainless steel
1160	1	1	1	suction strainer	steel		stainless steel
1165	4	4	4	bolt	stainless steel		
1300 *	1	1	1	gasket	---		
1310	2	2	2	plug	steel		stainless steel
1315	2 ¹⁾	2 ¹⁾	2 ¹⁾	sealing ring	nylon		
1800	2)	2)	2)	tap bolt	stainless steel		
1805	2)	2)	2)	washer	stainless steel		
1820	1	1	1	cap nut	bronze		stainless steel
1860 *	1	1	1	flat key	stainless steel		
2000	1	1	1	lantern piece	steel		stainless steel
2160	1	1	1	gasket	---		
2170	1	1	1	gasket	---		
3510	-	1	2	pipe	stainless steel		
3520	-	1	2	threaded coupling	stainless steel		
3525	-	1	2	sealing ring	nylon		
3530	-	1	2	T-union female (push fit)	stainless steel		
3540	1	1	1	socket	stainless steel		
3560	1	1	1	pipe nipple	stainless steel		
3570	1	1	1	threaded coupling	stainless steel		
3580	1	1	1	pipe	stainless steel		
3590	1	1	1	threaded coupling	stainless steel		
3600	-	1	2	intermediate bearing	cast iron		stainless steel
3610*	-	1	2	slide bearing sleeve, intermediate bearing	stainless steel + SSiC		
3620*	-	9	18	set screw	stainless steel		
3625*	-	1	2	dowel pin	stainless steel		
3630*	-	1	2	slide bearing, intermediate bearing	stainless steel + SSiC		
3640*	1	1	1	slide bearing, impeller side	stainless steel + SSiC		
3650*	1	1	1	slide bearing sleeve, impeller side	stainless steel + SSiC		
3660	-	1	2	coupling sleeve	bronze		stainless steel
4000	1	1	1	motor	---		
4010	3)	3)	3)	bolt	steel		
4020	3)	3)	3)	nut	steel		
4025	3)	3)	3)	washer	steel		
5010	8	8	8	tap bolt	stainless steel		
5015	8	8	8	washer	stainless steel		

Item Nr.	Quantity			Description	Materials		
	A	B	C		G1	G2	R6
5030	-	16	32	tap bolt	stainless steel		
5045	-	16	32	washer	stainless steel		
5050	8	8	8	tap bolt	stainless steel		
5055	8	8	8	washer	stainless steel		
5060	-	1	1	pump shaft,drive side	stainless steel		
5070	-	1	1	stand pipe, drive side	steel	stainless steel	
5080	-	1	1	stand pipe, impeller side	steel	stainless steel	
5100	-	1	1	pump shaft, impeller side	stainless steel		
5200	-	-	1	intermediate stand pipe	steel	stainless steel	
5210	-	-	1	intermediate pump shaft	stainless steel		
5220	1	-	-	stand pipe	steel	stainless steel	
5230	1	-	-	pump shaft	stainless steel		
6000	1	1	1	base plate	steel		
6020 *	1	1	1	oil baffle	NBR/spring steel		
6030	1	1	1	grease nipple	galvanized steel		
6040	4	4	4	Allen screw	steel		
6050 ⁴⁾	1	1	1	shimming ring	steel		
6060	1	1	1	oil baffle	NBR/spring steel		
6065	1	1	1	inner ring	stainless steel		
6070	1	1	1	flat key	steel		
6080	1	1	1	bearing cover	cast iron		
6090	1	1	1	spacer ring	steel		
6100	1	1	1	bearing nut	steel		
6105	1	1	1	locking ring	steel		
6110 *	1	1	1	double row angular contact ball bearing	---		
6120	4	4	4	tap bolt	steel		
6125	4	4	4	washer	steel		
6130	1	1	1	bearing support	steel		
6140	8	8	8	tap bolt	steel		
6145	8	8	8	washer	steel		
6150	1	1	1	earthing boss	copper		
6160	1	1	1	number plate	stainless steel		
6170	4	4	4	lifting lug	steel		
6180	1	1	1	arrow indication plate	stainless steel		
7035	4	4	4	adjusting cam	steel		
7036	4	4	4	bolt	stainless steel		
7037	8	8	8	bolt	steel		
7040	1	1	1	coupling half, drive side	cast iron/rubber		
7060	1	1	1	coupling half, pump side	cast iron/rubber		
7110	1	1	1	guard	steel		
7120	-	2	4	pipe fastener	stainless steel		
7130	-	2	4	bolt	stainless steel		
7135	-	2	4	nut	stainless steel		

Item Nr.	Quantity			Description	Materials		
	A	B	C		G1	G2	R6
7140	-	1	2	strip	stainless steel		
7150	-	1	2	strip	stainless steel		
8010	1	1	1	delivery section straight	steel	stainless steel	
8020	1	1	1	delivery section bend 90°	steel	stainless steel	
8030	2	2	2	gasket	---		
8035	1	1	1	gasket	---		
8040	1	1	1	pipe	steel	stainless steel	
8050	2	2	2	welding neck flange	steel	stainless steel	
8060	2)	2)	2)	tap bolt	stainless steel		
8065	2)	2)	2)	washer	stainless steel		
8070	2)	2)	2)	tap bolt	stainless steel		
8075	2)	2)	2)	washer	stainless steel		
8080	1	1	1	bend	steel	stainless steel	
8090	2)	2)	2)	tap bolt	stainless steel		
8100	2)	2)	2)	nut	stainless steel		
8105	2)	2)	2)	washer	stainless steel		

A = without intermediate bearing

B = with 1 intermediate bearing

C = with 2 intermediate bearings

1) If mounted, depending on pump type

2) Quantity 4, 8 or 16, depending on pump type

3) Quantity 4 or 8, depending on motor type

4) Determine thickness on assembly.

9.3.2 Parts list
See figure 16.

Item Nr.	Quantity			Description	Materials		
	A	B	C		G1	G2	R6
1100	1	1	1	pump casing	cast iron		stainless steel
1110	1	1	1	stuffing box cover	cast iron		stainless steel
1120 *	1	1	1	impeller	cast iron	bronze	stainless steel
1130 *	1 ¹⁾	1 ¹⁾	1 ¹⁾	wear ring	cast iron	bronze	stainless steel
1150	1	1	1	reducing flange	steel		stainless steel
1160	1	1	1	suction strainer	steel		stainless steel
1165	4	4	4	bolt	stainless steel		
1300 *	1	1	1	gasket	---		
1310	2	2	2	plug	steel	stainless steel	
1315	2 ¹⁾	2 ¹⁾	2 ¹⁾	sealing ring	nylon		
1800	2)	2)	2)	tap bolt	stainless steel		
1805	2)	2)	2)	washer	stainless steel		
1820	1	1	1	cap nut	bronze	stainless steel	
1860 *	1	1	1	flat key	stainless steel		
2000	1	1	1	lantern piece	steel	stainless steel	
2010 *	4	4	4	packing ring	---		
2020 *	1	1	1	lantern ring	bronze	stainless steel	
2030	1	1	1	gland	cast iron	stainless steel	
2040	2	2	2	stud	stainless steel		
2050	2	2	2	nut	brass	stainless steel	
2060 *	1	1	1	shaft sleeve	stainless steel		
2070 *	1	1	1	O-ring	viton		
2080	3	3	3	set screw	stainless steel		
2100	1	1	1	seal housing	steel	stainless steel	
2110	4	4	4	Allen screw	steel	stainless steel	
2120	1	1	1	pipe nipple	stainless steel		
2130	1	1	1	elbow	stainless steel		
2140	1	1	1	grease cup, spring loaded	brass		
2160	1	1	1	O-ring	---		
2170	1	1	1	gasket	---		
3510	-	1	2	pipe	stainless steel		
3520	-	1	2	threaded coupling	stainless steel		
3525	-	1	2	sealing ring	nylon		
3530	-	1	2	T-union female (push fit)	stainless steel		
3540	1	1	1	socket	stainless steel		
3560	1	1	1	pipe nipple	stainless steel		
3570	1	1	1	threaded coupling	stainless steel		
3580	1	1	1	pipe	stainless steel		
3590	1	1	1	threaded coupling	stainless steel		
3600	-	1	2	intermediate bearing	cast iron	stainless steel	
3610 *	-	1	2	slide bearing sleeve, intermediate bearing	stainless steel + SSiC		

Item Nr.	Quantity			Description	Materials		
	A	B	C		G1	G2	R6
3620 *	-	9	18	set screw	stainless steel		
3625	-	1	2	dowel pin	stainless steel		
3630 *	-	1	2	slide bearing, intermediate bearing	stainless steel + SSiC		
3640 *	1	1	1	slide bearing, impeller side	stainless steel + SSiC		
3650 *	1	1	1	slide bearing sleeve, impeller side	stainless steel + SSiC		
3660	-	1	2	coupling sleeve	bronze	stainless steel	
4000	1	1	1	motor	---		
4010	3)	3)	3)	bolt	steel		
4020	3)	3)	3)	nut	steel		
4025	3)	3)	3)	washer	steel		
5010	8	8	8	tap bolt	stainless steel		
5015	8	8	8	washer	stainless steel		
5030	-	16	32	tap bolt	stainless steel		
5035	-	16	32	tap bolt	stainless steel		
5050	8	8	8	tap bolt	stainless steel		
5055	8	8	8	washer	stainless steel		
5060	-	1	1	pump shaft, drive side	stainless steel		
5070	-	1	1	stand pipe, drive side	steel	stainless steel	
5080	-	1	1	stand pipe, impeller side	steel	stainless steel	
5100	-	1	1	pump shaft, impeller side	stainless steel		
5200	-	-	1	intermediate stand pipe	steel	stainless steel	
5210	-	-	1	intermediate pump shaft	stainless steel		
5220	1	-	-	stand pipe	steel	stainless steel	
5230	1	-	-	pump shaft	stainless steel		
6000	1	1	1	base plate	steel		
6020 *	1	1	1	oil baffle	NBR/spring steel		
6030	1	1	1	grease nipple	galvanized steel		
6040	4	4	4	Allen screw	steel		
6050 ⁴⁾	1	1	1	shimming ring	steel		
6060	1	1	1	oil baffle	NBR/spring steel		
6065	1	1	1	inner ring	stainless steel		
6070	1	1	1	flat key	steel		
6080	1	1	1	bearing cover	cast iron		
6090	1	1	1	spacer ring	steel		
6100	1	1	1	bearing nut	steel		
6105	1	1	1	locking ring	steel		
6110 *	1	1	1	double row angular contact ball bearing	---		
6120	4	4	4	tap bolt	steel		
6125	4	4	4	washer	steel		
6130	1	1	1	bearing support	steel		
6140	8	8	8	tap bolt	steel		
6145	8	8	8	washer	steel		

Item Nr.	Quantity			Description	Materials		
	A	B	C		G1	G2	R6
6150	1	1	1	earthing boss	copper		
6160	1	1	1	number plate	stainless steel		
6170	4	4	4	lifting lug	steel		
6180	1	1	1	arrow indication plate	stainless steel		
7035	4	4	4	adjusting cam	steel		
7036	4	4	4	bolt	stainless steel		
7037	8	8	8	bolt	steel		
7040	1	1	1	coupling half, drive side	cast iron/rubber		
7060	1	1	1	coupling half, pump side	cast iron/rubber		
7110	1	1	1	guard	steel		
7120	-	2	4	pipe fastener	stainless steel		
7130	-	2	4	bolt	stainless steel		
7135	-	2	4	nut	stainless steel		
7140	-	1	2	strip	stainless steel		
7150	-	1	2	strip	stainless steel		
8010	1	1	1	delivery section straight	steel		stainless steel
8020	1	1	1	delivery section bend 90°	steel		stainless steel
8030	2	2	2	gasket	---		
8035	1	1	1	gasket	---		
8040	1	1	1	pipe	steel		stainless steel
8050	2	2	2	welding neck flange	steel		stainless steel
8060	2)	2)	2)	tap bolt	stainless steel		
8065	2)	2)	2)	washer	stainless steel		
8070	2)	2)	2)	tap bolt	stainless steel		
8075	2)	2)	2)	washer	stainless steel		
8080	1	1	1	bend	steel		stainless steel
8090	2)	2)	2)	tap bolt	stainless steel		
8100	2)	2)	2)	nut	stainless steel		
8105	2)	2)	2)	washer	stainless steel		

A = without intermediate bearing

B = with 1 intermediate bearing

C = with 2 intermediate bearings

1) If mounted, depending on pump type

2) Quantity 4, 8 or 16, depending on pump type

3) Quantity 4 or 8, depending on motor type

4) Determine thickness on assembly.

9.4 Pump with shaft sealing group M2

9.4.1 Sectional drawing

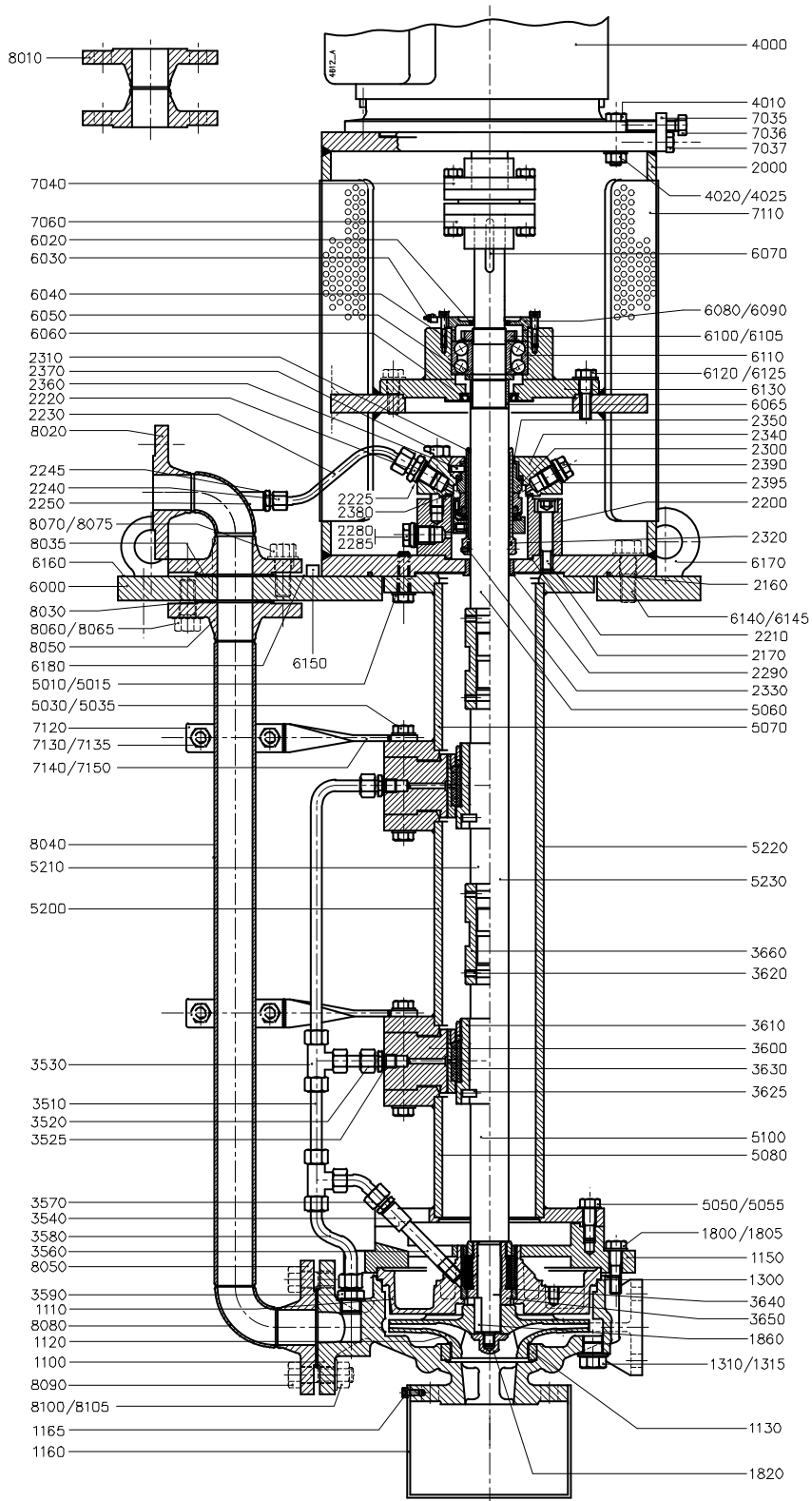

Figure 17: Pump with shaft sealing group M2.

9.4.2 Parts list

See figure 17.

Item Nr.	Quantity			Description	Materials		
	A	B	C		G1	G2	R6
1100	1	1	1	pump casing	cast iron		stainless steel
1110	1	1	1	stuffing box cover	cast iron		stainless steel
1120 *	1	1	1	impeller	cast iron	bronze	stainless steel
1130 *	1 ¹⁾	1 ¹⁾	1 ¹⁾	wear ring	cast iron	bronze	stainless steel
1150	1	1	1	reducing flange	steel		stainless steel
1160	1	1	1	suction strainer	steel		stainless steel
1165	4	4	4	bolt	stainless steel		
1300 *	1	1	1	gasket	---		
1310	2	2	2	plug	steel	stainless steel	
1315	2 ¹⁾	2 ¹⁾	2 ¹⁾	sealing ring	nylon		
1800	2)	2)	2)	tap bolt	stainless steel		
1805	2)	2)	2)	washer	stainless steel		
1820	1	1	1	cap nut	bronze	stainless steel	
1860 *	1	1	1	flat key	stainless steel		
2000	1	1	1	lantern piece	steel	stainless steel	
2160	1	1	1	O-ring	---		
2170	1	1	1	gasket	---		
2200	1	1	1	seal housing	steel	stainless steel	
2210	4	4	4	Allen screw	steel	stainless steel	
2220	1	1	1	threaded coupling	stainless steel		
2225	1	1	1	sealing ring	nylon		
2230	1	1	1	pipe	stainless steel		
2240	1	1	1	threaded coupling	stainless steel		
2245	1	1	1	sealing ring	nylon		
2250	1	1	1	socket	steel	stainless steel	
2280	1	1	1	plug	steel	stainless steel	
2285	1	1	1	sealing ring	nylon		
2290 *	1	1	1	throttling bush	bronze	stainless steel	
2300 *	1	1	1	mechanical seal	---		
2310	1	1	1	shaft sleeve	stainless steel		
2320 *	1	1	1	O-ring	viton		
2330	3	3	3	set screw	stainless steel		
2340	1	1	1	mechanical seal cover	stainless steel		
2350 *	1	1	1	throttling bush	PTFE		
2360	1	1	1	locking pin	stainless steel		
2370	4	4	4	tap bolt	steel	stainless steel	
2380 *	1	1	1	gasket	---		
2390	1	1	1	plug	stainless steel		
2395	1	1	1	sealing ring	nylon		
3510	-	1	2	pipe	stainless steel		
3520	-	1	2	threaded coupling	stainless steel		
3525	-	1	2	sealing ring	nylon		

Item Nr.	Quantity			Description	Materials		
	A	B	C		G1	G2	R6
3530	-	1	2	T-union female (push fit)	stainless steel		
3540	1	1	1	socket	stainless steel		
3560	1	1	1	pipe nipple	stainless steel		
3570	1	1	1	threaded coupling	stainless steel		
3580	1	1	1	pipe	stainless steel		
3590	1	1	1	threaded coupling	stainless steel		
3600	-	1	2	intermediate bearing	cast iron	stainless steel	
3610 *	-	1	2	slide bearing sleeve, intermediate bearing	stainless steel + SSiC		
3620 *	-	9	18	set screw	stainless steel		
3625	-	1	2	dowel pin	stainless steel		
3630 *	-	1	2	slide bearing, intermediate bearing	stainless steel + SSiC		
3640 *	1	1	1	slide bearing, impeller side	stainless steel + SSiC		
3650 *	1	1	1	slide bearing sleeve, impeller side	stainless steel + SSiC		
3660	-	1	2	coupling sleeve	bronze	stainless steel	
4000	1	1	1	motor	---		
4010	3)	3)	3)	bolt	steel		
4020	3)	3)	3)	nut	steel		
4025	3)	3)	3)	washer	steel		
5010	8	8	8	tap bolt	stainless steel		
5015	8	8	8	washer	stainless steel		
5030	-	16	32	tap bolt	stainless steel		
5035	-	16	32	tap bolt	stainless steel		
5050	8	8	8	tap bolt	stainless steel		
5055	8	8	8	washer	stainless steel		
5060	-	1	1	pump shaft, drive side	stainless steel		
5070	-	1	1	stand pipe, drive side	steel	stainless steel	
5080	-	1	1	stand pipe, impeller side	steel	stainless steel	
5100	-	1	1	pump shaft, impeller side	stainless steel		
5200	-	-	1	intermediate stand pipe	steel	stainless steel	
5210	-	-	1	intermediate pump shaft	stainless steel		
5220	1	-	-	stand pipe	steel	stainless steel	
5230	1	-	-	pump shaft	stainless steel		
6000	1	1	1	base plate	steel		
6020 *	1	1	1	oil baffle	NBR/spring steel		
6030	1	1	1	grease nipple	galvanized steel		
6040	4	4	4	Allen screw	steel		
6050 ⁴⁾	1	1	1	shimming ring	steel		
6060	1	1	1	oil baffle	NBR/spring steel		
6065	1	1	1	inner ring	stainless steel		
6070	1	1	1	flat key	steel		
6080	1	1	1	bearing cover	cast iron		
6090	1	1	1	spacer ring	steel		
6100	1	1	1	bearing nut	steel		
6105	1	1	1	locking ring	steel		
6110 *	1	1	1	double row angular contact ball bearing	---		

Item Nr.	Quantity			Description	Materials		
	A	B	C		G1	G2	R6
6120	4	4	4	tap bolt	steel		
6125	4	4	4	washer	steel		
6130	1	1	1	bearing support	steel		
6140	8	8	8	tap bolt	steel		
6145	8	8	8	washer	steel		
6150	1	1	1	earthing boss	copper		
6160	1	1	1	number plate	stainless steel		
6170	4	4	4	lifting lug	steel		
6180	1	1	1	arrow indication plate	stainless steel		
7035	4	4	4	adjusting cam	steel		
7036	4	4	4	bolt	stainless steel		
7037	8	8	8	bolt	steel		
7040	1	1	1	coupling half, drive side	cast iron/rubber		
7060	1	1	1	coupling half, pump side	cast iron/rubber		
7110	1	1	1	guard	steel		
7120	-	2	4	pipe fastener	stainless steel		
7130	-	2	4	bolt	stainless steel		
7135	-	2	4	nut	stainless steel		
7140	-	1	2	strip	stainless steel		
7150	-	1	2	strip	stainless steel		
8010	1	1	1	delivery section straight	steel	stainless steel	
8020	1	1	1	delivery section bend 90°	steel	stainless steel	
8030	2	2	2	gasket	---		
8035	1	1	1	gasket	---		
8040	1	1	1	pipe	steel	stainless steel	
8050	2	2	2	welding neck flange	steel	stainless steel	
8060	2)	2)	2)	tap bolt	stainless steel		
8065	2)	2)	2)	washer	stainless steel		
8070	2)	2)	2)	tap bolt	stainless steel		
8075	2)	2)	2)	washer	stainless steel		
8080	1	1	1	bend	steel	stainless steel	
8090	2)	2)	2)	tap bolt	stainless steel		
8100	2)	2)	2)	nut	stainless steel		
8105	2)	2)	2)	washer	stainless steel		

A = without intermediate bearing

B = with 1 intermediate bearing

C = with 2 intermediate bearings

- 1) If mounted, depending on pump type
- 2) Quantity 4, 8 or 16, depending on pump type
- 3) Quantity 4 or 8, depending on motor type
- 4) Determine thickness on assembly.

9.5 Pump with shaft sealing group S0, bearing bracket group 4

9.5.1 Sectional drawing

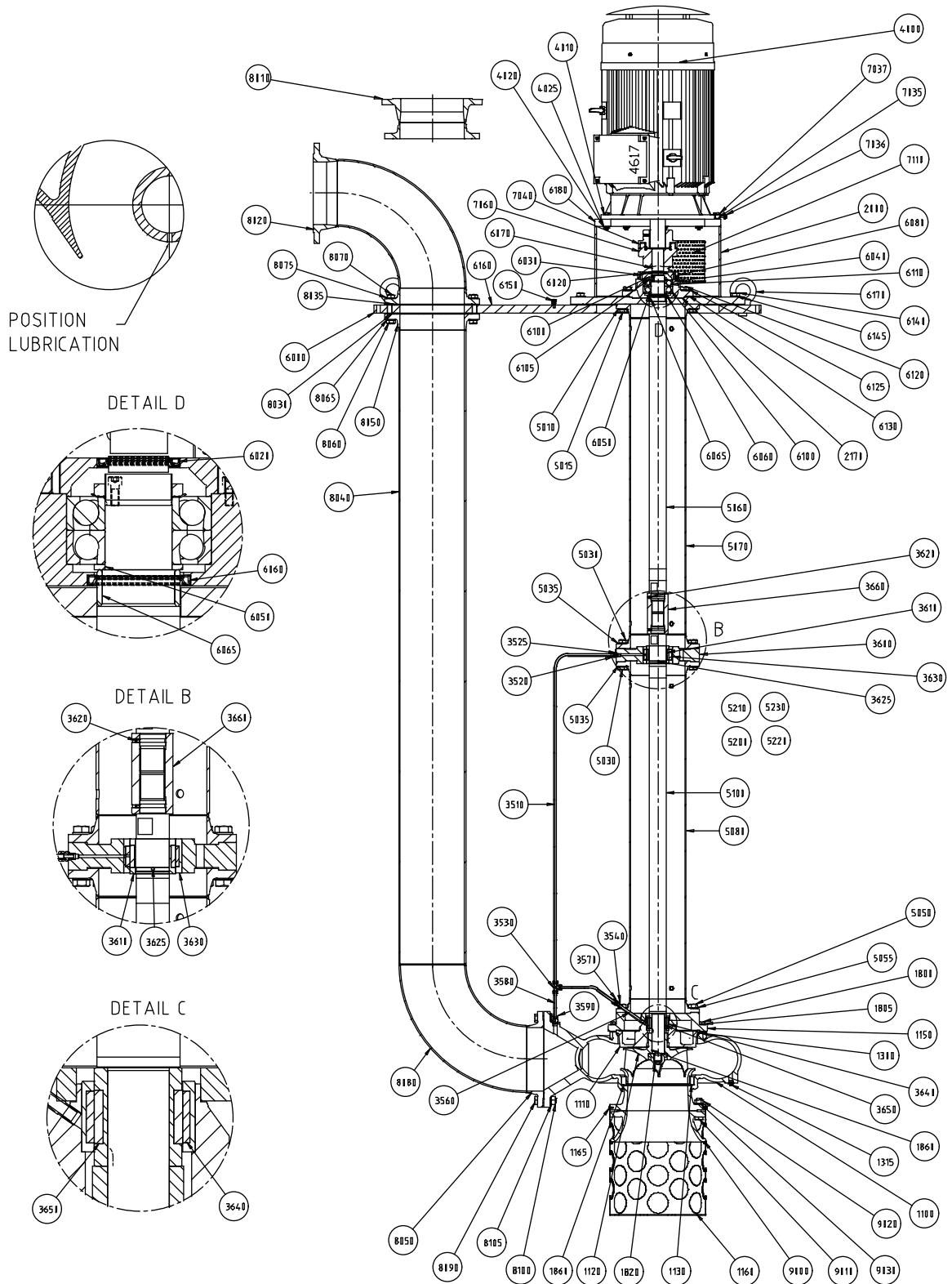

Figure 18: Pump with shaft sealing group S0, bearing bracket group 4.

9.5.2 Parts list
See figure 18.

Item Nr.	Quantity			Description	Materials		
	A	B	C		G1	G2	R6
1100	1	1	1	pump casing	cast iron		stainless steel
1110	1	1	1	stuffing box cover	cast iron		stainless steel
1120 *	1	1	1	impeller	cast iron	bronze	stainless steel
1130 *	1 ¹⁾	1 ¹⁾	1 ¹⁾	wear ring	cast iron	bronze	stainless steel
1150	1	1	1	reducing flange	steel		stainless steel
1160	1	1	1	suction strainer	steel		stainless steel
1165	4	4	4	bolt	stainless steel		
1300 *	1	1	1	gasket	---		
1310	2	2	2	plug	steel	stainless steel	
1800	2)	2)	2)	tap bolt	stainless steel		
1805	2)	2)	2)	washer	stainless steel		
1820	1	1	1	cap nut	bronze	stainless steel	
1860 *	1	1	1	flat key	stainless steel		
2000	1	1	1	lantern piece	steel	stainless steel	
2160	1	1	1	gasket	---		
2170	1	1	1	gasket	---		
3510	-	1	2	pipe	stainless steel		
3520	-	1	2	threaded coupling	stainless steel		
3525	-	1	2	sealing ring	nylon		
3530	-	1	2	T-union female (push fit)	stainless steel		
3540	1	1	1	socket	stainless steel		
3560	1	1	1	pipe nipple	stainless steel		
3570	1	1	1	threaded coupling	stainless steel		
3580	1	1	1	pipe	stainless steel		
3590	1	1	1	threaded coupling	stainless steel		
3600	-	1	2	intermediate bearing	cast iron	stainless steel	
3610*	-	1	2	slide bearing sleeve, intermediate bearing	stainless steel + SSiC		
3620*	-	9	18	set screw	stainless steel		
3625*	-	2	4	dowel pin	stainless steel		
3630*	-	1	2	slide bearing, intermediate bearing	stainless steel + SSiC		
3640*	1	1	1	slide bearing, impeller side	stainless steel + SSiC		
3650*	1	1	1	slide bearing sleeve, impeller side	stainless steel + SSiC		
3660	-	1	2	coupling sleeve	bronze	stainless steel	
4000	1	1	1	motor	---		
4010	3)	3)	3)	bolt	steel		
4020	3)	3)	3)	nut	steel		
4025	3)	3)	3)	washer	steel		
5010	12	12	12	tap bolt	stainless steel		
5015	12	12	12	washer	stainless steel		
5030	-	24	48	tap bolt	stainless steel		
5045	-	24	48	washer	stainless steel		

Item Nr.	Quantity			Description	Materials		
	A	B	C		G1	G2	R6
5050	12	12	12	tap bolt	stainless steel		
5055	12	12	12	washer	stainless steel		
5060	-	1	1	pump shaft, drive side	steel	stainless steel	
5070	-	1	1	stand pipe, drive side	steel	stainless steel	
5080	-	1	1	stand pipe, impeller side	steel	stainless steel	
5100	-	1	1	pump shaft, impeller side	steel	stainless steel	
5200	-	-	1	intermediate stand pipe	steel	stainless steel	
5210	-	-	1	intermediate pump shaft	steel	stainless steel	
5220	1	-	-	stand pipe	steel	stainless steel	
5230	1	-	-	pump shaft	steel	stainless steel	
6000	1	1	1	base plate	steel		
6020 *	1	1	1	oil baffle	NBR/spring steel		
6030	1	1	1	grease nipple	galvanized steel		
6040	4	4	4	Allen screw	steel		
6050 4)	1	1	1	shimming ring	steel		
6060	1	1	1	oil baffle	NBR/spring steel		
6065	1	1	1	inner ring	stainless steel		
6070	1	1	1	flat key	steel		
6080	1	1	1	bearing cover	cast iron		
6100	1	1	1	bearing nut	steel		
6105	1	1	1	locking ring	steel		
6110 *	2	2	2	single row angular contact ball bearing	---		
6120	4	4	4	tap bolt	steel		
6125	4	4	4	washer	steel		
6130	1	1	1	bearing support	steel		
6140	8	8	8	tap bolt	steel		
6145	8	8	8	washer	steel		
6150	1	1	1	earthing boss	copper		
6160	1	1	1	number plate	stainless steel		
6170	4	4	4	lifting lug	steel		
6180	1	1	1	arrow indication plate	stainless steel		
7035	4	4	4	adjusting cam	steel		
7036	4	4	4	bolt	stainless steel		
7037	8	8	8	bolt	steel		
7040	1	1	1	coupling half, drive side	cast iron/rubber		
7060	1	1	1	coupling half, pump side	cast iron/rubber		
7110	1	1	1	guard	steel		
8010	1	1	1	delivery section straight	steel	stainless steel	
8020	1	1	1	delivery section bend 90°	steel	stainless steel	
8030	2	2	2	gasket	---		
8035	1	1	1	gasket	---		
8040	1	1	1	pipe	steel	stainless steel	
8050	2	2	2	welding neck flange	steel	stainless steel	

Item Nr.	Quantity			Description	Materials		
	A	B	C		G1	G2	R6
8060	2)	2)	2)	tap bolt	stainless steel		
8065	2)	2)	2)	washer	stainless steel		
8070	2)	2)	2)	tap bolt	stainless steel		
8075	2)	2)	2)	washer	stainless steel		
8080	1	1	1	bend	steel	stainless steel	
8090	2)	2)	2)	tap bolt	stainless steel		
8100	2)	2)	2)	nut	stainless steel		
8105	2)	2)	2)	washer	stainless steel		
9000 ⁵⁾	1	1	1	bell mouth	stainless steel		
9010 ⁵⁾	4	4	4	tap bolt	stainless steel		
9020 ⁵⁾	4	4	4	nut	stainless steel		
9030 ⁵⁾	4	4	4	washer	stainless steel		

A = without intermediate bearing
 B = with 1 intermediate bearing
 C = with 2 intermediate bearings

- 1) If mounted, depending on pump type
- 2) Quantity 4, 8 or 16, depending on pump type
- 3) Quantity 4 or 8, depending on motor type
- 4) Determine thickness on assembly.
- 5) Available on request.

10 Technical data

10.1 Grease

Table 5: Recommended greases according to NLGI-2 classification.

BP	Energrease LS 2
SHELL	Alvania R2
MOBIL	Mobilux EP 2
TOTAL	Multis EP-22
CHEVRON	Polyurea EP Grease-2
ESSO	Beacon 2
FINA	Marson L2
TEXACO	MultifaK EP-2
SKF	Alfalub LGMT 3

10.2 Recommended greases for assembly

Recommended Anti-seize paste for the thread of the shaft parts:

- 'Never Seez'

Recommended greases for greasening stuffing packing rings:

- Foliac Cup grease (graphite grease)
- MolyCote BR2 (graphite grease)
- Silicon grease

10.3 Recommended locking liquids

Table 6: Recommended locking liquids.

Description	Locking liquid
cap nut (1820)	Loctite 243
throttling bush (2290)/(2350)	Loctite 641
wear ring (1130)	

10.4 Tightening moments

10.4.1 Tightening moments for bolts and nuts

Table 7: Tightening moments for bolts and nuts.

Materials	8.8	A2, A4
Thread	Tightening moment [Nm]	
M6	9	6
M8	20	14
M10	40	25
M12	69	43
M16	168	105

10.4.2 Tightening moments for cap nut

Table 8: Tightening moments for cap nut (1820).

Materials	A2, A4	Bronze G-CuSn12
Size	Tightening moment [Nm]	
M12 (bearing group 1)	43	15
M16 (bearing group 2)	105	36
M24 (bearing group 3)	220	119
M24 (bearing group 4)	510	412

10.5 Operational range

CS	Max. impeller Ø [mm]	Back vane Ø [mm] *st.st. impeller: no back vanes.	Internal width impeller [mm]		Max. speed [min ⁻¹]		Max. working pressure [bar] at 50°C	
			G1/G2	R6	X1	X2	X1	X2
32-125	139	76	6,5	8	3600	3600	16	16
32-160	169	76*	7	8	3600	3600	16	16
32-200	209	130*	4,5	8	3600	3600	16	16
32-250	260	161	6	8	3000	3600	16	16
40-125	139	76	10	10	3600	3600	16	16
40-160	169	120	8	8	3600	3600	16	16
40-200	209	110	9	9	3600	3600	16	16
40-250	260	150	7	8	3000	3600	16	16
40-315	320	164	7	7	1800	3000	16	16
50-125	139	115	21	21	3600	3600	10	16
50-160	169	118	12	12	3600	3600	10	16
50-200	209	155	9,5	9,5	3600	3600	10	16
50-250	260	160	11	11	3000	3600	10	16
50-315	320	208	8	8	1800	3000	16	16
65-125	139	139	26	26	3600	3600	10	16
65-160	173	156	26	26	3600	3600	10	16
65-200	209	157	15	15	3600	3600	10	16
65-250	260	186	11	11	3000	3600	10	16
65-315	320	200	13,5	13,5	1800	3000	10	16
80-160	179	179	25,3	25,5	3600	3600	10	16
80-200	214	187	22	22	3600	3600	10	16
80-250	260	225	19,5	19,5	3000	3000	10	16
80-315	320	239	12,5	12,5	1800	3000	10	16
80-400	410	277	7	7	1800	1800	16	16
100-125	160	160	27	-	3600		10	
100-160	190	190	33	-	3600		10	
100-200	220	200	30		3000	3000	16	16
100-250	269	235	17	17	3000	3000	16	16
100-315	324	243	16	16	1800	1800	16	16
100-400	410	231	11	11	1800	1800	16	16
125-125	164	153	44,5		1800		10	
125-250	269	234	28	28	1800	1800	16	16
125-315	324	272	26	26	1800	1800	16	16
125-400	404	299	18,5	18,5	1800	1800	16	16
125-500	530	384	13		1500		10	
150-125	172	162	43,5		1800		10	
150-160	200	186	47		1800		10	
150-200	224	224	36		1800		10	
150-250	273	273	42,5		1800		10	
150-315	325	304	52		1500		10	
150-400	415	342	29		1500		10	

CS	Max. impeller Ø [mm]	Back vane Ø [mm] *st.st. impeller: no back vanes.	Internal width impeller [mm]		Max. speed [min ⁻¹]		Max. working pressure [bar] at 50°C	
			G1/G2	R6	X1	X2	X1	X2
150B-400	340	384	32		1800		10	
150-500	525	400	23,5		1500		10	
200-200	244	236	52		1800		10	
200-250	310	296	47		2400		10	
200-315	345	337	45		2400		10	
200-400	438	415	41		1700		10	
250-200	252	243	67		1800		10	
250-250	310	297	85		1900		10	
250-315	345	337	45		2000		10	
300-250	345	332	92		1500		10	
300-315	365	365	90		1500		10	

10.6 Maximum allowable working pressures

Table 9: Maximum allowable working pressure [kPa] (according to ISO 7005-2/3)

Materials	Max. temperature [°C]		
	50	120	150
Cast iron G1	1000	1000	900
Cast iron G2	1600	1600	1440
Stainless steel R6	1600	1400	1300

100 kPa = 1 bar

Test pressure: 1,5 x max. working pressure.

Table 10: Maximum operating conditions of the shaft seals

Shaft sealing groups	Max. admissible working pressure [kPa]	Max. temperature [°C]
S0	1600	105
S3	1600	105
M2	1600	160 *

* Higher temperatures in consultation. Depends on the liquid to be pumped

- For shaft sealing group S0 an over-pressure of 0,5 bar in the suction pit or tank is permitted.

10.7 Liquid level

A sufficiently high liquid level is required to ensure proper operation of the pump. If the liquid level is too low, air may be aspirated. The so-called "vortex effect" then occurs, which not only affects the performance of the pump, but can also seriously damage the pump as a result of vibrations, cavitation or insufficient lubrication of the slide bearing. The "vortex effect" occurs when the suction speed in the pump is so high that strong vortices occur in the liquid.

In the dimension drawings, size mp represents the minimum liquid level at which the pump may be started (with a closed delivery valve). The impeller and, if appropriate, the bottom slide bearing are then placed far enough in the liquid. In the graph below, however, the required liquid in relation to the pump inlet opening is indicated according to the flow rate and the inlet diameter of the pump. Depending on the duty point of the pump, this minimum liquid level should be taken into account.

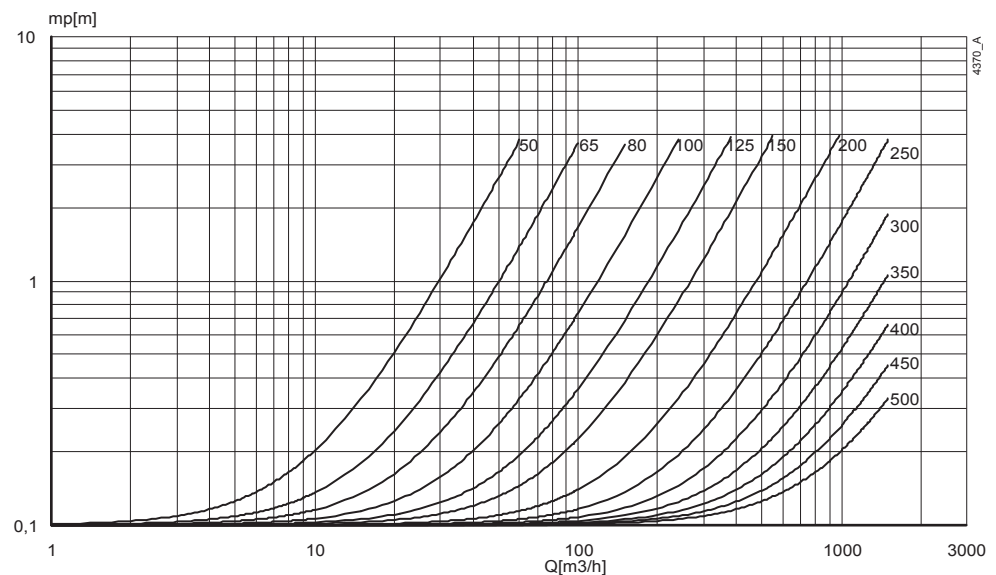

Figure 19: Lowest level of the liquid as a function of the capacity and the entry diameter.

10.8 Noise data

10.8.1 Pump noise as a function of pump power

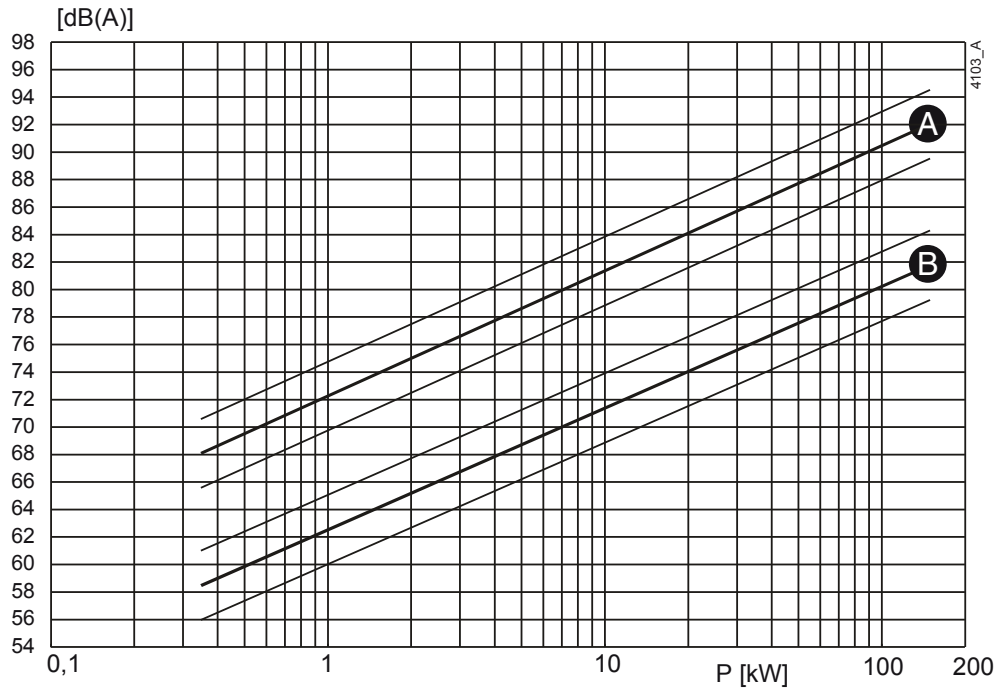

Figure 20: Noise level as function of pump power [kW] at 1450 min^{-1}
A = sound energy, B = sound pressure.

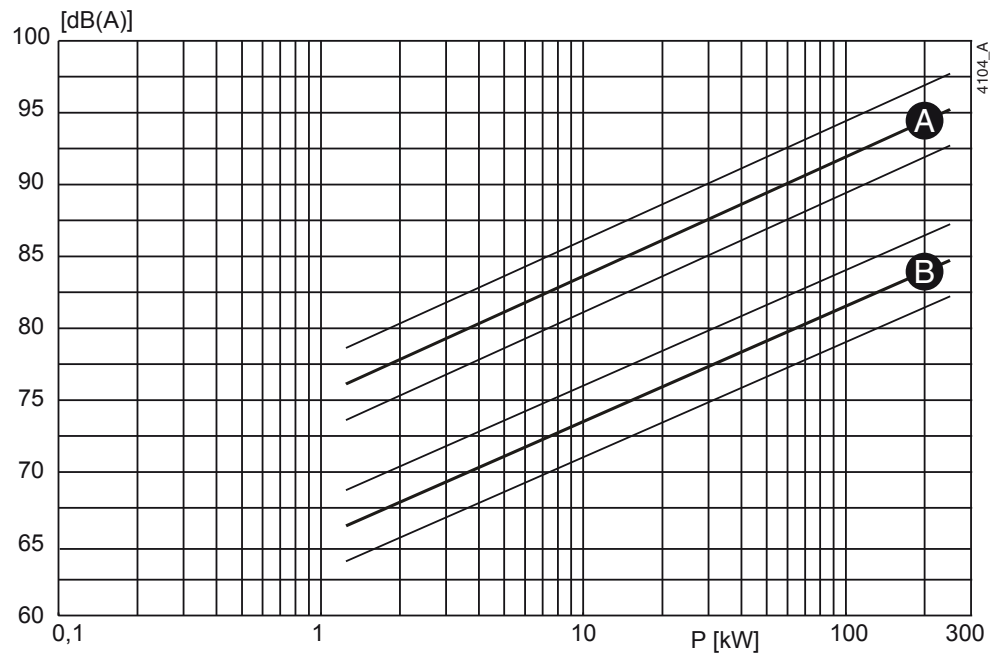

Figure 21: Noise level as function of pump power [kW] at 2900 min^{-1}
A = sound energy, B = sound pressure.

10.8.2 Noise level of entire pump unit

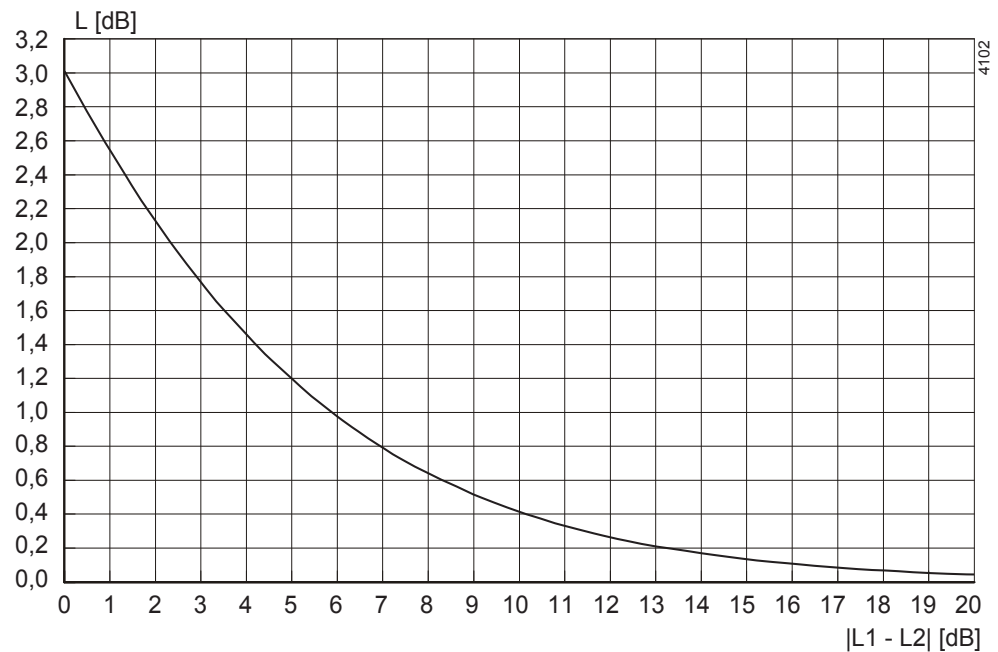

Figure 22: Noise level of entire pump unit.

In order to determine the total noise level of the entire pump unit, the noise level of the motor must be added to that of the pump. This can be easily done by using the graph above.

- 1 Determine the noise level (L1) of the pump, see figure 20 or figure 21.
- 2 Determine the noise level (L2) of the motor, see documentation of the motor.
- 3 Determine the difference between both levels $|L1 - L2|$.
- 4 Find the differential value on the $|L1 - L2|$ -axis and go up to the curve.
- 5 From the curve go left to the L[dB] -axis and read out the value.
- 6 Add this value to the highest value of both noise levels (L1 or L2).

Example:

1. Pump 75 dB; motor 78 dB.
2. $|75-78| = 3$ dB.
3. 3 dB on the X-axis = 1,75 dB on the Y-axis.
4. Highest noise level + 1,75 dB = 78 + 1,75 = 79,75 dB.

Index

A

Application area	15
Applications	14

B

Ball bearings	
lubrication	24
Bearing groups	14

C

Commissioning	21
Construction	14
dry part	14
pump casing/impeller	14
shaft sealing	15
submersible part	14
Construction variants	27
Coupling	
alignment	19
alignment tolerances	20
fitting	18

D

Daily maintenance	23
mechanical seal	23
stuffing box packing	23
Designation of parts	27

E

Earthing	17
Electric motor	
connecting	18
sense of rotation	18
Environment	17
Environmental influences	24

F

Faults	24
Flushing liquid	23
Foundation	17

G

Grease	61
Greases for assembly	61
Guarantee	10

H

Hoisting	11
----------------	----

I

Inspection	
pump	21

L

Lifting eye	11
Liquid draining	28
Liquid level	21, 65

M

Maintenance staff	9
Max. allowable working pressure	64
Mechanical seal	22

N

Noise	22, 24
-------------	--------

O

Operational range	63
-------------------------	----

P

Pallets	10
Piping	20
Position numbers	27
Precautionary measures	27
Pump description	13

R

Recommended greases	61
Recommended locking liquid	61
Re-use	15

S
Safety9, 17
 symbols9
Scrapping15
Serial number14
Special tools27
Static electricity17
Storage 10, 12
Stuffing box packing
 adjustment22

T
Technicians9
Tightening moments
 for bolts and nuts62
 for cap nut62
Transport10
Type description13

U
Unit
 assembling18
 mounting18
 placing18

V
Ventilation17

W
Wear ring
 assembly34
 disassembly34
Working switch18



Your local contact:



SPX Process Equipment NL B.V.
Dr. A. F. Philipsweg 51, 9403 AD Assen, THE NETHERLANDS
P.O. Box 9, 9400 AA Assen, THE NETHERLANDS
Phone: + 31 (0) 592 37 67 67 Fax: + 31 (0) 592 37 67 60
E-Mail: johnson-pump.nl@processequipment.spx.com

For more information about our worldwide locations, approvals, certifications, and local representatives, please visit www.johnson-pump.com / www.spxpe.com.

SPX Corporation reserves the right to incorporate our latest design and material changes without notice or obligation. Design features, materials of construction and dimensional data, as described in this bulletin, are provided for your information only and should not be relied upon unless confirmed in writing.

Copyright © 2005, 2009 SPX Corporation